

Controlling Recidivism Among Released Inmates: How Can Education Programs Be Better Used to Reduce Their Rates?

Benjamin Cabrera¹, Auroni Hashim², and Marcia Hawkins-Day³

¹Arizona State University

²Muhlenberg College

³Siena Heights University

July 31, 2021

Abstract

The Center for public Safety Initiatives defines recidivism in criminal justice as the tendency for convicted persons to re-offend within three years of their release. The economic impact of incarceration per-inmate in the US is \$31,286 per year which creates a great burden for the States due to the approximately 2.2 million people incarcerated [36]. Many previous studies, such as the ones performed by the non-profit RAND corporation provide substantial support for prison education to reduce (or better allocate) taxpayer and government spending. We aim to quantify the impact of higher education beyond vocational, literacy, and trade school on recidivism rates in United States' prisons by measuring the impact of education programs in the dynamics of the incarcerated population. We hypothesize that the implementation of these programs lowers recidivism, therefore reducing the economic burden for the States. We propose two compartmental models that capture different states of criminal activity with and without educational program enrollment. With an estimated \$182 billion spent yearly in order to run the US corrections system and it's associated costs [36].

We analyzed its influence on the dynamics of recidivism for California and Delaware which have contrasting availability of education programs for incarcerated people, with California running more successful in contrast to Delaware which has few education programs, none of has been very successful or which offer anything beyond GED certification. Our methods for analysis include analyzing equilibrium points and running numerical simulations. The simulations presented in the paper illustrate the effects of higher education on recidivism; education programs, especially those which have been established as successful, reduce recidivism. To explore these effects we examine two different states: Delaware and California. Delaware has few higher education programs in its prison system but California has many well established programs. Additionally, Delaware also has the nation's second highest recidivism rate at 64.9% [14]. Our results support what the social sciences have proposed: education programs in state prisons

lower recidivism. Furthermore, we observed that by implementing a successful education system into a prison system that has previously been deprived of it, the number of recidivists goes down by almost two hundred fold in 10 years.

1 Introduction

The incarcerated population in United States' prisons has increased by 700% since the 1970s [1]. While the United States makes up less than 5% of the world's population, it contributes 25% of the world's prison population [2]. When discussing tools to combat mass incarceration, it is crucial to understand the concept of recidivism. Recidivism is defined as the tendency for a formerly incarcerated person to re-offend within three years after their release. Recidivism provides information on how effective the criminal justice system is. Incarceration comes at a high cost to taxpayers and the state with an estimate of \$182 billion spent annually to run the corrections system and its associated costs [35]. It is important to study recidivism to explore different ways to mitigate these high costs. Research in the social sciences has revealed that the existence of correctional education in the prison system is correlated with lower rates of recidivism. Educational opportunities provide the incarcerated population with an increased chance of higher quality employment after their release, reducing recidivism [32]. Many prisons offer adult basic education and secondary education, however, formerly incarcerated people who were able to get a college degree in prison have lower recidivism rates than those who received vocational training or earned a GED in prison [2].

Reducing recidivism has significant financial benefits [7]. A meta-analysis of previous studies has shown that inmates who participate in education programs have significantly lower odds of returning to prison than those who have not participated in education programs [32]. These studies provide substantial support in favor of prison education as a means to reduce (or better allocate) taxpayer and government spending [32]. More specifically, every dollar spent on prison education programs saves between four and five dollars on the cost of recidivism[7]. The vast majority of the research regarding recidivism and correctional education been carried out through the focus of various social sciences; with little research using a mathematical or quantitative approach [9] [10] [6] [4]. Applying a quantitative approach to the problem reducing recidivism through education allows us to model the dynamics of incarceration and the impact of education on the probability to recidivate.

Thus, with both of these models we plan to answer the following research questions:

- How do correctional higher education programs reduce recidivism?
- How do changes in enrollment in higher education affect recidivism?

In the social sciences, it is well established that correctional education programs are integral to reducing recidivism. In an article by Brett Dignam et al. [2] explore how lack of education in prisons negatively affects both the incarcerated and the community. The authors make a case for providing higher education to prison populations. One example they provide of the positive impact of higher education funding for prisoners is the Pell Grant, a grant funded by the federal government that was the largest source of aid for post-secondary undergraduate education. In 1994, Pell Grant funding was no longer available to inmates. This had an devastating effect as it was found that by 1997, prisoner enrollment in higher education programs had decreased by forty percent. Higher education was largely responsible for improvements in prisons such as lower rates of recidivism, lower disciplinary infractions as well as being an important factor in improving race-relations. Dignam et al.

summarize that providing public funding for higher education in prisons not only improves public safety but also saves money by lowering the rate of recidivism [2].

Similarly, some mathematical models have captured different dynamics of the prison system. Lum et al.[10], hypothesized the “transmissibility” of incarceration by using an *SIS* model to analyze the dynamics of two different prison populations. *S* describes the susceptible population while *I* describes the incarcerated population. The rate of movement from *I* to *S*, *s*, is the length of an individual’s prison sentence. Using this model, the authors were able to demonstrate that small differences in sentencing can result in large disparities in incarceration rates. This conclusion is based on the social network influence of those incarcerated. Since we considered this to be a relevant finding, we decided to incorporate social interactions into our model.

In an article by McMillon et al. [9], the authors present multiple compartmental models which are used in order to capture the dynamics of crime. Using many models with varying levels of complexity, the authors are able to examine the effects of longer prison terms and provide the analytical tipping points between high-crime and low-crime equilibrium points [9]. This paper was the basis for the model created in the research presented below.

The goal of our research is to use the application of quantitative methods to assess the effect of higher education programs in the United States’ prison system. To do this, we study two different states: Delaware and California. These two states were chosen because of their contrasting availability of higher education programs in prison. In Delaware, there were few higher education in prison programs in 2020 [33]. On the other hand, California had 34 of these programs in 2020 [33]. Furthermore, California has many well established higher education programs such as the Prison University Project which operated out of Patten University in collaboration with San Quentin State Prison [34]. This program was so successful for over twenty years that the program became a candidate for accreditation from the Accrediting Commission of Community and Junior Colleges [34]. Presently, the Prison University Project is called Mount Tamalpais College. Because of these differences, we chose Delaware and California parameters for our simulation parameters to exemplify the effect of higher education. This research aims to put math and social science in conversation by using mathematical methods informed by social structures, with the goal to quantify the impact correctional education programs have on lower (or higher) recidivism rates with the intention to reduce the number of incarcerated individuals in US prisons; we will use mathematical analysis to compare the results from our two models.

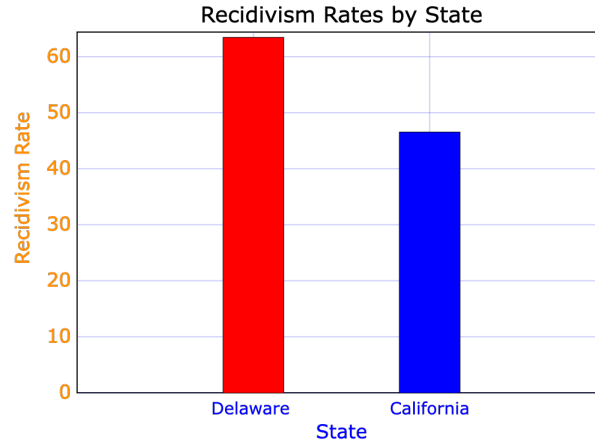

This report is organized as follows: we present the methodology and the formulation of the model followed by the results including numerical simulations. Lastly, we discuss the results, state some conclusions, and provide possible directions for future research.

2 Methodology

The research question this paper aims to answer is: How do correctional higher education programs reduce recidivism? To address the research question, we will expand on the model proposed by McMillon et al. [9] pictured in figure 1. This model was created to explore the dynamics of crime in the United States. This model is a system of ordinary differential equations with five compartments in table 1. (1) X , those who are not criminally active at a given time; (2) C_1 , those who are criminally active but have never been incarcerated; (3) I , those who are incarcerated at a given time; (4) R , those who were once incarcerated but are not criminally active; (5), C_2 , those who were once incarcerated and are again criminally active. This final class encompasses the recidivists.

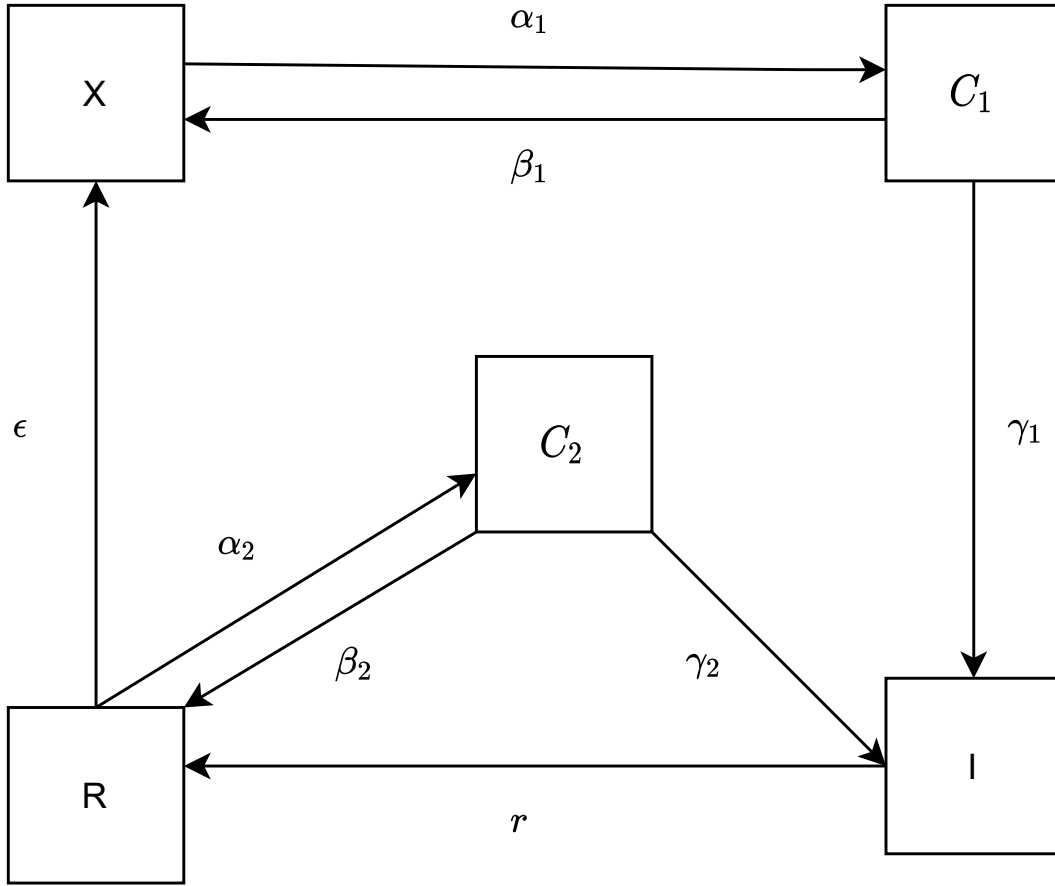

Figure 1: Dynamics of Crime from [9]

The the system of ordinary differential equations for the model for the McMillon et al. [9] model are listed below in Equation 1.

Table 1: Recidivism Model Classes

Symbol	Description
X_N	No Criminal Behavior
C_1	Criminal Behavior, No Recidivists
C_2	Criminal Behavior, Repeat Offender
I	Incarcerated
R	Released from Prison System

$$\begin{aligned}
\dot{X} &= -\alpha_1 X + \beta_1 C_1 + \epsilon R \\
\dot{C}_1 &= -\gamma_1 C_1 + \alpha_1 X - \beta_1 C_1 \\
\dot{I} &= \gamma_1 C_1 - rI + \gamma_2 C_2 \\
\dot{R} &= rI - \alpha_2 R + \beta_2 C_2 - \epsilon R \\
\dot{C}_2 &= \alpha_2 R - \beta_2 C_2 - \gamma_2 C_2
\end{aligned} \tag{1}$$

2.1 Dynamics of Prison without Education Programs

Our baseline model, pictured in Figure 2, demonstrates the dynamics of the prison system without education programs beginning with the compartments describing individuals prior to incarceration. The X_N class represents individuals that do not engage in criminal behavior, while the X_C class describes individuals who are at risk of engaging in criminal behavior. The X_C class was created to address the fact that in the general population individuals not involved in criminal activity are not equally as likely to partake in criminal activity as those who are. The C_1 class represents individuals who are engaged in criminal activity that could lead them to incarceration. Incarcerated individuals, represented by the I class, are then released entering the R class. Following departure from the R class there are two possible outcomes, the first being individuals who return to criminal activity entering the C_2 class, and the second being individuals who move to X_N and return to a life without criminal behavior. Prisoners who recidivate will move from the C_2 back to the I class, therefore returning to a state of incarceration. We do not show any dynamics of prisoners who return back to a normal life since individuals in the released class transition either back to prison or immediately back to a person with no criminal behavior. This model operates under the following assumptions:

1. There is homogeneous mixing of the population.
2. Recidivism occurs within three years of release.
3. Those who recidivate get incarcerated at the same rate as first time offenders.
4. Demographic changes will only occur in the not criminally active class.
5. Those who recidivate and no longer partake in criminal activity will return to the X_N class.
6. “At-risk” is defined as a sum of a proportion of the population that is below the poverty rate and a proportion of the population that has a low educational attainment.

Assumption (2) follows the definition of recidivism provided by many US states [3]. Following the definition provided by many states is important, because policymakers use this definition to supplement their discussions on new legislation [3].

The flow diagram, compartment descriptions (Table 2), equations (Equation 2), and parameter table (Table 3) for the proposed (baseline) model without education programs are as follows:

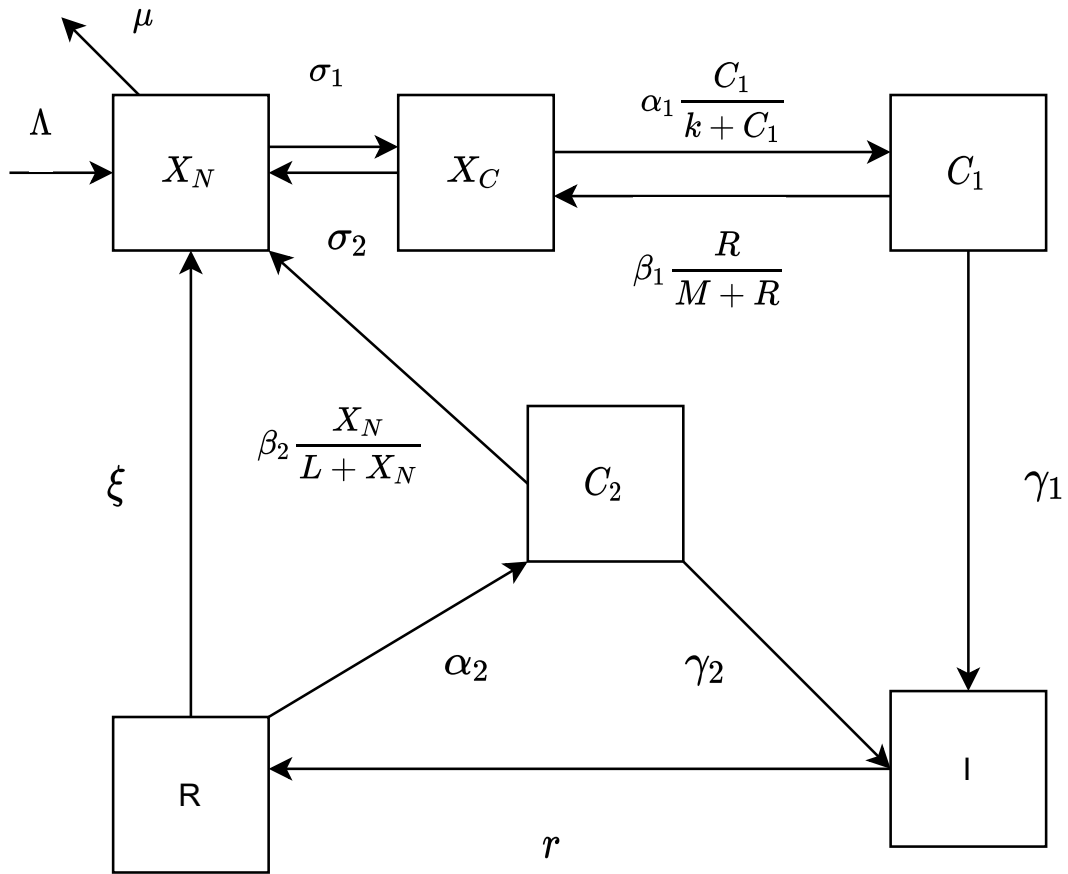

Figure 2: Proposed Model (No Higher Education Programs)

Table 2: Recidivism Model Classes

Symbol	Description
X_N	No Criminal Behavior
X_C	At Risk of Criminal Behavior
C_1	Criminal Behavior, No Recidivists
C_2	Criminal Behavior, Repeat Offender
I	Incarcerated
R	Released from Prison System

$$\begin{aligned}
\dot{X}_N &= \Lambda - \mu X_N - \sigma_1 X_N + \sigma_2 X_C + \xi R + \beta_2 \frac{X_N}{L + X_N} C_2 \\
\dot{X}_C &= \sigma_1 X_N - \sigma_2 X_C - \alpha_1 \frac{C_1}{k + C_1} X_C \\
\dot{C}_1 &= \alpha_1 \frac{C_1}{k + C_1} X_C - \beta_1 \frac{R}{M + R} C_1 - \gamma_1 C_1 \\
\dot{I} &= \gamma_1 C_1 + \gamma_2 C_2 - rI \\
\dot{R} &= rI - \alpha_2 R - \xi R \\
\dot{C}_2 &= \alpha_2 R - \beta_2 \frac{X_N}{L + X_N} C_2 - \gamma_2 C_2
\end{aligned} \tag{2}$$

Table 3: Recidivism Model Parameters

Symbol	Description	Value	Source
α_1	Per capita criminality rate	0.00000007946278564	[15]
α_2	Per capita recidivism rate	0.0000006510817816	[16]
γ_1	Per capita first-time incarceration rate	0.0000003060289762	[17]
γ_2	Per capita incarceration rate (for recidivists)	0.0000006777822963	[18]
β_1	Per capita decriminality rate of non-recidivists	0.0000007209131567	[17]
β_2	Per capita decriminality rate of recidivists	0.0000003758603196	[16]
r	Per capita release rate	0.0000003949610122	[19]
ξ	Per capita conversion rate from released to general population	0.0000003758595477	[16]
σ_1	Per capita rate of general population becoming at-risk for criminal behavior	0.0000001342604556	[28]
σ_2	Per capita rate of population at-risk for criminal behavior returns to general population	0.0000005134682728	[29]
Λ	Immigration/entry rate	38014	[30]
μ	Per capita exit rate	0.00000002991592332	[30]

2.2 Dynamics of Prison with Enrollment in Education Programs

For our model that implements education, shown in figure 3, we have additional compartments and terms compared to the baseline model in order to capture the dynamics of

prisoners who participate in educational programs. The initial transitions from X_N to X_C to C_1 remain the same. However, in this model the incarcerated class, I , is split into two. The I_N class represents inmates who are not enrolled in an education program while incarcerated, and the I_E represents inmates who enroll in education programs while incarcerated. Hence, all individuals who become incarcerated enter the I_N class and can move to the I_E class as they enroll in a correctional education program. Another difference in the education model lies in the transition from incarceration from I_N and I_E to release. In the education model, we have chosen to split the released class into R_N , which represents released inmates who did not participate in an education program, and R_E , which represents released inmates who did participate in an education program. Following this transition, the two compartments have similar movements. An individual in R_N can return to criminal behavior by moving to C_2 or return to X_N where they cease criminal behavior. Similarly, individuals in the R_E class can either return to criminal behavior by moving to C_2 or return to X_N . We hypothesize that individuals participating in education programs will have a better success at finding work after release which will result in a lower recidivism rate for the participating component. This model operates under the following assumptions:

1. There is homogeneous mixing of the population
2. Recidivism occurs within three years of release.
3. Those who recidivate get incarcerated at the same rate as first time offenders.
4. Demographic changes will only occur in the not criminally active class.
5. Those who recidivate and no longer partake in criminal activity will return to the X_N class.
6. Those who enroll in an education program do not return to the not enrolled in an education program class.
7. Everyone who becomes incarcerated must enter prison not enrolled in a program. Input into this population comes from two sources: C_1 and C_2 .
8. “At-risk” is defined as a sum of a proportion of the population that is below the poverty rate and a proportion of the population that has a low educational attainment.

Similar to the baseline model, assumption (2) follows the definition of recidivism provided by many US states [3]. Following the definition provided by many states is important, because policymakers use this definition to supplement their discussions on new legislation [3].

Our proposed model with education adds three different classes to follow the dynamics of recidivism based on education. This model has I_N and I_E classes in replacement of I , as well as R_E and R_N in replacement of R . These changes can be seen in the following equations and Figure 3.

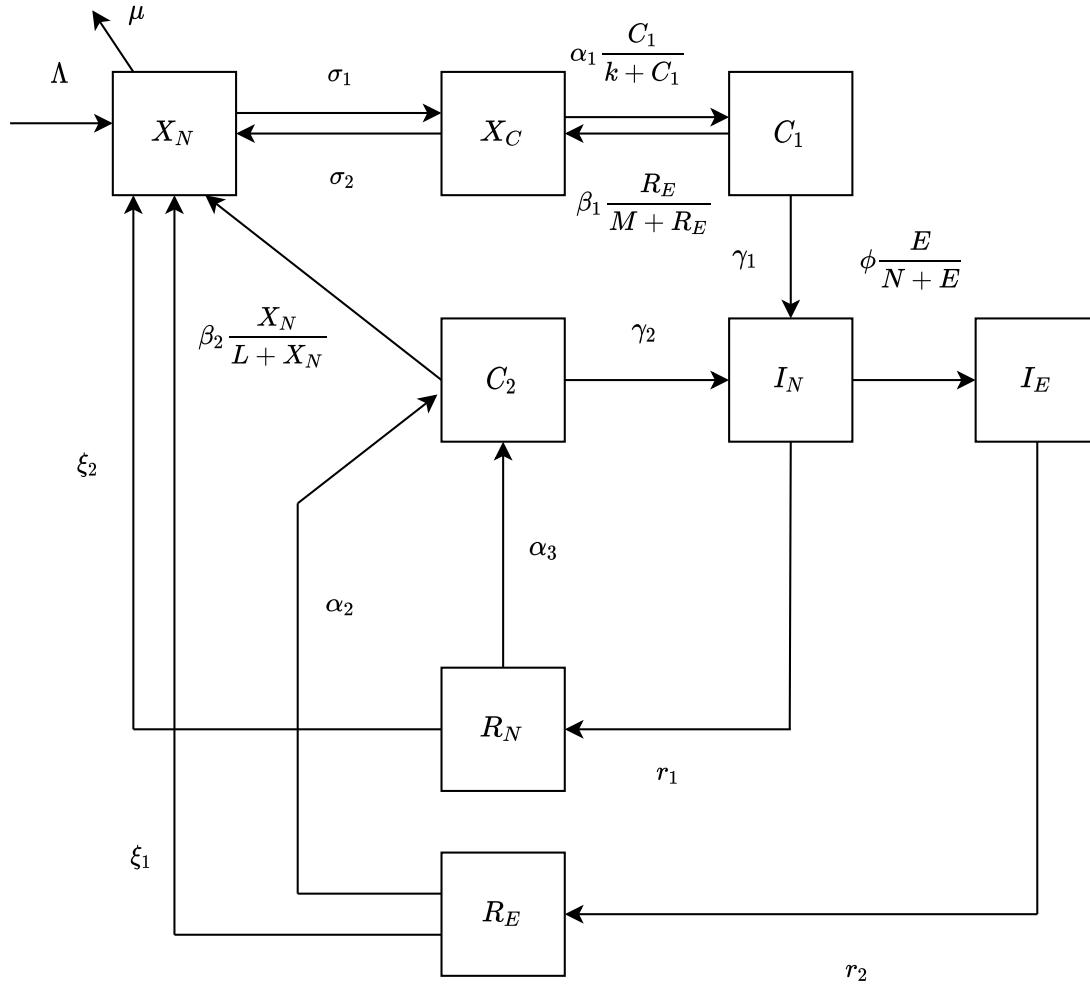

Figure 3: Proposed Model (With Higher Education Programs)

Table 4: Recidivism Model Classes

Symbol	Description
X_N	No Criminal Behavior
X_C	At Risk of Criminal Behavior
C_1	Criminal Behavior, No Recidivists
C_2	Criminal Behavior, Repeat Offender
I_N	Incarcerated, Not Enrolled in Education Program
I_E	Incarcerated, Enrolled in Education Program
R_N	Released from Prison System, Never Enrolled in Education Program
R_E	Released from Prison System, Previously Enrolled in Education Program

$$\begin{aligned}
\dot{X}_N &= \Lambda - \mu X_N + \xi_1 R_E + \xi_2 R_N + \beta_2 \frac{X_N}{L + X_N} C_2 - \sigma_1 X_N + \sigma_2 X_C \\
\dot{X}_C &= \sigma_1 X_N - \sigma_2 X_C - \alpha_1 \frac{C_1}{k + C_1} X_C + \beta_1 \frac{R_E}{M + R_E} C_1 \\
\dot{C}_1 &= \alpha_1 \frac{C_1}{k + C_1} X_C - \beta_1 \frac{R_E}{M + R_E} C_1 - \gamma_1 C_1 \\
\dot{I}_N &= \gamma_2 C_2 + \gamma_1 C_1 - r_1 I_N - \phi \frac{I_E}{N + I_E} I_N \\
\dot{I}_E &= \phi \frac{I_E}{N + I_E} I_N - r_2 I_E \\
\dot{R}_N &= r_1 I_N - \alpha_3 R_N - \xi_2 R_N \\
\dot{R}_E &= r_2 I_E - \alpha_2 R_E - \xi_1 R_E \\
\dot{C}_2 &= \alpha_3 R_N + \alpha_2 R_E - \beta_2 \frac{X_N}{L + X_N} C_2 - \gamma_2 C_2
\end{aligned} \tag{3}$$

Table 5: Recidivism Model (With Higher Education Programs) Parameters

Symbol	Description	Value	Source
α_1	Per capita criminality rate	0.025514	[31]
α_2	Per capita recidivism rate (enrolled)	0.000000009376844999	[24]
α_3	Per capita recidivism rate (not enrolled)	0.0005245460373	[25]
γ_1	Per capita first-time incarceration rate	0.3819999903	[17]
γ_2	Per capita recidivist incarceration rate	0.6599999666	[18]
β_1	Per capita decriminality rate of non-recidivists	0.6179999531	[17]
β_2	Per capita decriminality rate of recidivists	0.3399999656	[18]
r_1	Per capita not enrolled inmate release rate	0.3845999513	[19]
r_2	Per capita enrolled inmate release rate	0.3845999416	[19]
ξ_1	Per capita conversion rate from released (education program)to general population (no further criminal behavior)	0.00000001593177606	[24]
ξ_2	Per capita conversion rate from released (no education program)to general population (no further criminal behavior)	0.000000008858016648	[25]
ϕ	Per capita rate of entrance into education program	0.3329999242	[26]
σ_1	Per capita rate of general population becoming at-risk for criminal behavior	0.1579703723	[28]
σ_2	Per capita rate of at-risk population for criminal behavior returns to general population	0.4999998608	[29]
Λ	Immigration/entry rate	141300	[27]
μ	Per capita exit rate	0.01999999342	[27]

2.3 Parameter Estimation

The following parameters were estimated:

α_1 For the Delaware parameters, the per capita criminality rate was found by finding the total number of serious crimes committed and dividing that by the state population. For the California parameters, the per capita criminality rate was found by finding the sum of property crimes and violent crimes committed and dividing that by the state population.

r The per capita release rate was found by taking the reciprocal of the average prison stay.

σ_1 The rate for the general population to become at risk for criminal behavior was estimated through two factors: poverty level and education attainment. The probability for an individual in poverty to become at risk for criminal behavior was multiplied by the proportion of individuals in poverty for both California and Delaware. This was added to the proportion of inmates who did not possess a high school diploma multiplied by the proportion of individuals in each state who did not possess a high school diploma.

2.4 Model Formulation

No criminal behavior (X_N)

This compartment contains the portion of the general population which does not participate in crime. We consider the demographics, i.e. that the (state) population will increase by the entry rate Λ representing newborn and people who move into the state, and that the population will decrease at a per capita exit rate μ as people move away from the state or die. As individuals in this compartment become at risk of participating in crime, they will leave X_N at a rate of σ_1 and enter X_C , where they become a part of the general population at (more) risk of committing crime. Once an individual becomes a part of the X_C class, they may leave the at-risk portion of the general population moving them to the X_N compartment at a rate of σ_2 . Individuals also move to the X_N class once released from prison. If they were enrolled in an education program during their time in prison, they enter this compartment at rate ξ_1 . Similarly, if they were not enrolled in an education program during their time in prison, they enter at rate ξ_2 . Another way individuals can enter the X_N class is to reactivate and no longer participate in criminal activity. This happens at a rate of $\beta_2 \frac{X_N}{L+X_N}$. Thus, the rate of change of general population is given by the differential equation:

$$\dot{X}_N = \Lambda - \mu X_N + \xi_1 R_E + \xi_2 R_N + \beta_2 \frac{X_N}{L + X_N} C_2 - \sigma_1 X_N + \sigma_2 X_C \quad (4)$$

At risk of criminal behavior (X_C)

There are many characteristics that can classify someone as at-risk of criminal behavior. As stated in the assumptions, we defined “at-risk” as a sum of a proportion of the population that is below the poverty rate and a proportion of the population that has a low educational attainment [28]. This population increases by the incoming flow from general population becoming at-risk from criminal behavior at a rate of σ_1 and also the income of flow from the population no longer criminally active at a rate of $\beta_1 \frac{R_E}{M+R_E}$. This population decreases due to a return to involvement in crime at a rate of $\alpha_1 \frac{C_1}{k+C_1}$. Some of the individuals leave this compartment and return to the “no criminal behavior” class. This transition was estimated by the success rates of intervention programs available in the United States that help those at-risk of criminal behavior, which is at a rate of σ_2 . Thus, the rate of change this population is given by the differential equation:

$$\dot{X}_C = \sigma_1 X_N - \sigma_2 X_C - \alpha_1 \frac{C_1}{k + C_1} X_C + \beta_1 \frac{R_E}{M + R_E} C_1 \quad (5)$$

Criminally Active (C_1)

This compartment represents those who participate in criminal behavior but have not been caught or incarcerated for their actions. This population increases from the flow of individuals from the criminally active class at a rate of $\alpha_1 \frac{C_1}{k+C_1}$. This rate includes the social influence the criminally active have on those who are at-risk of criminal activity. Once someone is in the criminally active class they can leave in two ways: they can either return to the at-risk of criminal behavior population or the incarcerated population. Those who become incarcerated leave the criminally active compartment at a rate of γ_1 . Everyone who stops being criminally active becomes part of the at-risk of criminal behavior compartment at a rate of $\beta_1 \frac{R_E}{M+R_E}$. This rate includes a positive social influence from the people who were released from prison and took part of an education program in prison. Thus, the rate of change this population is given by the differential equation:

$$\dot{C}_1 = \alpha_1 \frac{C_1}{k+C_1} X_C - \beta_1 \frac{R_E}{M+R_E} C_1 - \gamma_1 C_1 + \omega_1 \frac{C_1}{L+C_1} X_N \quad (6)$$

Incarcerated, Not Enrolled (I_N)

The incarcerated class holds the prison population for the respective state being studied. This incarcerated class is not enrolled in an education program. We assume that everyone who becomes incarcerated must enter prison not enrolled in a program. Input into this population comes from two sources: classes C_1 and C_2 . That means that this model only allows flow into the incarcerated compartment if someone is criminally active and has never been incarcerated or if someone recidivates within three years of their release from prison. Those entering this class from C_1 come in at a rate of γ_1 and those entering this class from C_2 come in at a rate of γ_2 . The I class decreases if someone is released from prison or if they enroll into an education program. If someone is released from a prison from the I class, that means that they were not enrolled in an education program. This release happens at a rate of r_1 . Incarcerated people move into an education program at the rate of $\phi \frac{I_E}{N+I_E}$. This rate includes a Holling Type II number which makes the rate density dependent, $\phi \frac{I_E}{N+I_E}$. This represents the interactions those enrolled have with the not enrolled, which can influence the not enrolled to join an education program. Thus, the rate of change this population is given by the differential equation:

$$\dot{I}_N = \gamma_2 C_2 + \gamma_1 C_1 - r_1 I_N - \phi \frac{I_E}{N+I_E} I_N \quad (7)$$

Incarcerated, Enrolled (I_E)

The incarcerated, enrolled class refers to the incarcerated population enrolled in an education program. This class receives input from the E class and gives output to the R_E class. The E class gets flow from the incarcerated, not enrolled class at a rate of $\phi \frac{E}{N+E}$. This includes the density dependent social influence the enrolled have on the non-enrolled. Furthermore, this class decreases when the incarcerated people who are enrolled in education programs are released from prison. This transition happens at a rate of r_2 . Thus, the rate of change this population is given by the differential equation:

$$\dot{I}_E = \phi \frac{I_E}{N+I_E} I_N - r_2 I_E \quad (8)$$

Released, Not Enrolled (R_N)

The R_N class represents the population of released people who were not in an education program during their time in prison. This population is affected in three ways: the incoming flow from the I class and the outgoing flows to the C and X_N classes. This population increases when the people who were incarcerated and not in an education program are released at a rate of r_1 . It decreases when people recidivate, which happens at rate α_3 . If they do not recidivate within three years, they move back to the not criminally active compartment at rate ξ_2 . Thus, the rate of change this population is given by the differential equation:

$$\dot{R}_N = r_1 I_N - \alpha_3 R_N - \xi_2 R_N \quad (9)$$

Released, Enrolled (R_E)

The R_E class represents the population of released individuals who were in an education program during their time in prison. Similar to R_N , this population is affected in three ways: the incoming flow from the I class, the outgoing flow to the C class and instead of having an outgoing flow to the X_N class, the flow goes to the X_E class. This allows us to follow the dynamics of recidivism based on education. This population increases when incarcerated people enrolled in an education program are released at a rate of r_2 . The population decreases when people recidivate, which happens at a rate of α_2 . If they do not recidivate within three years, they move back to the not criminally active compartment at rate ξ_1 . Thus, the rate of change this population is given by the differential equation:

$$\dot{R}_E = r_2 I_E - \alpha_2 R_E - \xi_1 R_E \quad (10)$$

Criminal Behavior, Repeat Offender (C_2)

This compartment contains the recidivist population. People can enter this compartment if they are released from prison, which can happen in two ways. First, they were released from prison and did not participate in an education program. This population enters the C_2 class at rate α_3 . Second, they were released from prison and they did participate in an education program. This population enters the C_2 class at a rate α_2 . People leave this compartment by either returning to prison or returning to no criminal behavior. They can leave at a rate of $\beta_2 \frac{X_N}{L+X_N}$ to the not involved in criminal activity compartment. They can also return to incarceration at a rate of γ_2 . Thus, the rate of change this population is given by the differential equation:

$$\dot{C}_2 = \alpha_3 R_N + \alpha_2 R_E - \beta_2 \frac{X_N}{L+X_N} C_2 - \gamma_2 C_2 \quad (11)$$

Hence, the full model in it's entirety is as follows in Equation 3. The simplified model without education is as described in Equation 2.

3 Results

3.1 Crime-Free, and Recidivism-Free Equilibrium Points

For each of the models proposed (without education and with education), there is one recidivism-free equilibrium point. Crime-free means that the equilibrium values of four of the

state variables vanish: $C_1 = I = R = C_2 = 0$. It follows from the first two equations in (2) and (3) that the equilibrium points for each model are as follows: $E_0^* = (\frac{\Lambda}{\mu}, \frac{\sigma_1 \Lambda}{\sigma_2 \mu}, 0, 0, 0, 0)$, for the model without education, and for the model with education, $E_0^* = (\frac{\Lambda}{\mu}, \frac{\sigma_1 \Lambda}{\sigma_2 \mu}, 0, 0, 0, 0, 0, 0)$. This state of the dynamical system is not likely in real life, because quite certainly some individual will engage in criminal behavior.

Recidivism-free equilibrium points require that $C_2^* = 0$. The last equation in (3) then implies that $R_E^* = R_N^* = 0$, and then the penultimate and third-last equations in (3) imply that $I_E^* = I_N^* = 0$. Now the fourth equation in (3) implies that $C_1^* = 0$, making the recidivism-free equilibrium actually crime-free.

3.2 Numerical Simulations

To measure changes in recidivism, we will be using the ratio $\frac{C_2}{I_N + I_E}$ in our analysis. These values will be the same as each compartment's population size at the initial timestamp and after ten years. In most scenarios when incarceration decreases, so does recidivism. In these situations, it is hard to see based off of the raw numbers if education has no effect on recidivism or if it is the decreasing incarceration. So we created this metric to track the changes recidivism has when an education program is implemented, defunded, or has increased enrollment. If the ratio is equal to zero, there is no recidivism. If it is equal to one, everyone in prison is recidivating once they are released. This means that when the ratio is small, recidivism is proportionately low. If the ratio is large, recidivism is proportionately high.

3.2.1 Delaware Recidivism

The baseline model is founded on and simulated by data from the state of Delaware. The state of Delaware has no higher educational programs beyond a GED available to inmates in prisons within the state, and few higher educational programs in general. Additionally, Delaware also has the nation's second highest recidivism rate at 64.9% [14]. For these reasons, we have chosen to use the state of Delaware as the basis for our Recidivism Model without higher educational programs.

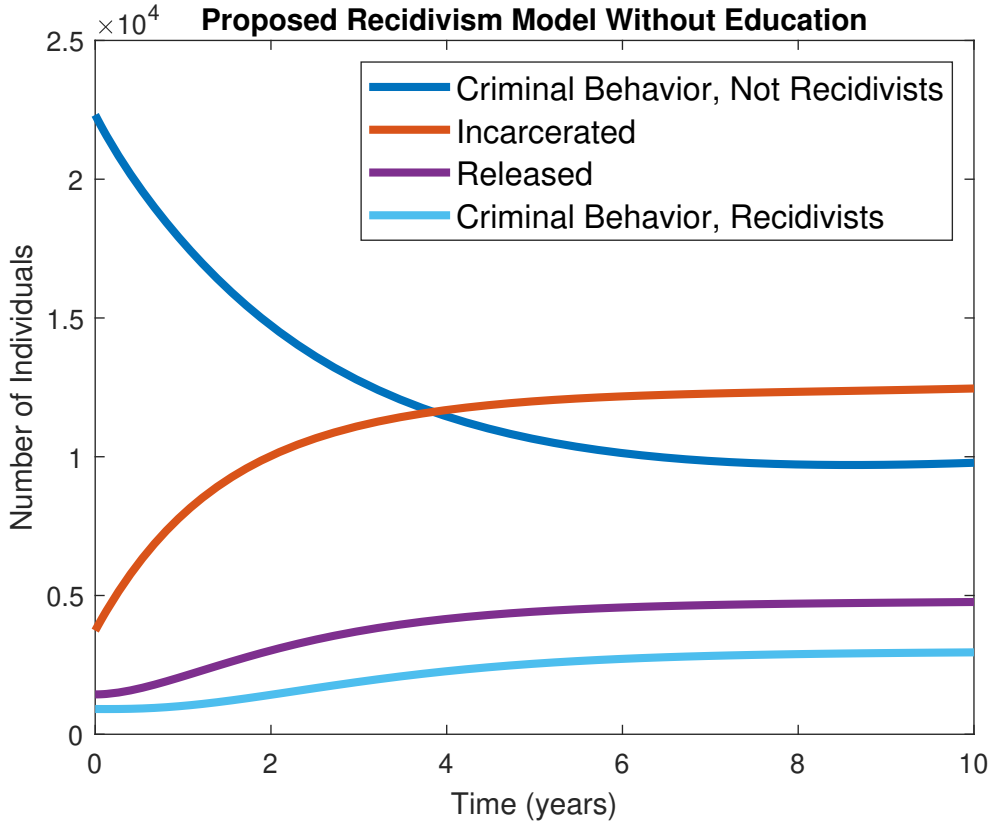

Figure 4: Simulation of Delaware Recidivism

The model without education simulation is pictured in figure 2. This model uses the equations represented in equation 2 and the parameters from table 3. We have chosen to exclude the X_N and X_C class in figure 4 as it makes it easier to view the dynamics of the other four classes. As time progresses there is an immediate decrease in C_1 class as there is an increase in the I class. This represents a reduction in the number of criminally active individuals as the number of incarcerated individuals rises. This is an accurate depiction of real-life dynamics because as more criminals are arrested, there will briefly be less criminals on the streets, and more criminals being introduced to the prison system. As time progresses each of the four classes in figure 4 continues to increase. In this simulation, Delaware initially has 910 recidivists in the C_2 class and 3,735 in the incarcerated I class, which results in a recidivist to incarcerated proportion $\frac{C_2}{I}$ of $\frac{910}{3735} \approx .2436$. After 5 years, the number of recidivists in the population is 2,536. After 10 years, the number of recidivists in the population is 2,951. At the final timestamp, the recidivist to incarcerated population ($\frac{C_2}{I}$) is $\frac{2951}{12460} \approx 0.2368$. Overall, this simulation reflects that in the absence of correctional higher educational programs, recidivism persists within the community.

3.2.2 Higher education in Delaware

The simulation below represents what would happen if Delaware implemented higher education programs in its prison system. The education parameters match the ones from

California, but the rest are from Delaware. The graph of the numerical simulation shows that if Delaware implemented an education system comparable to California it would see a decrease in recidivism. After 10 years, the number of recidivists in the population is only 7. At the final timestamp, the recidivist to incarcerated population is $\frac{6}{509+69} \approx 0.0103$.

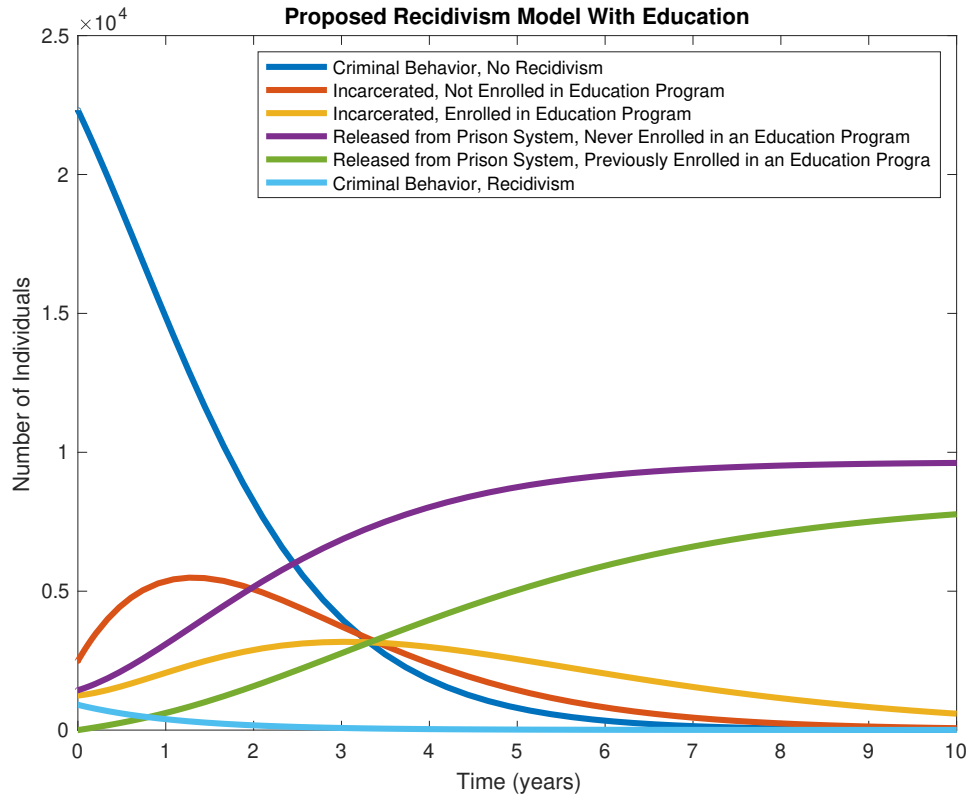

Figure 5: Simulation of Delaware Recidivism: Delaware Implements an Education Program

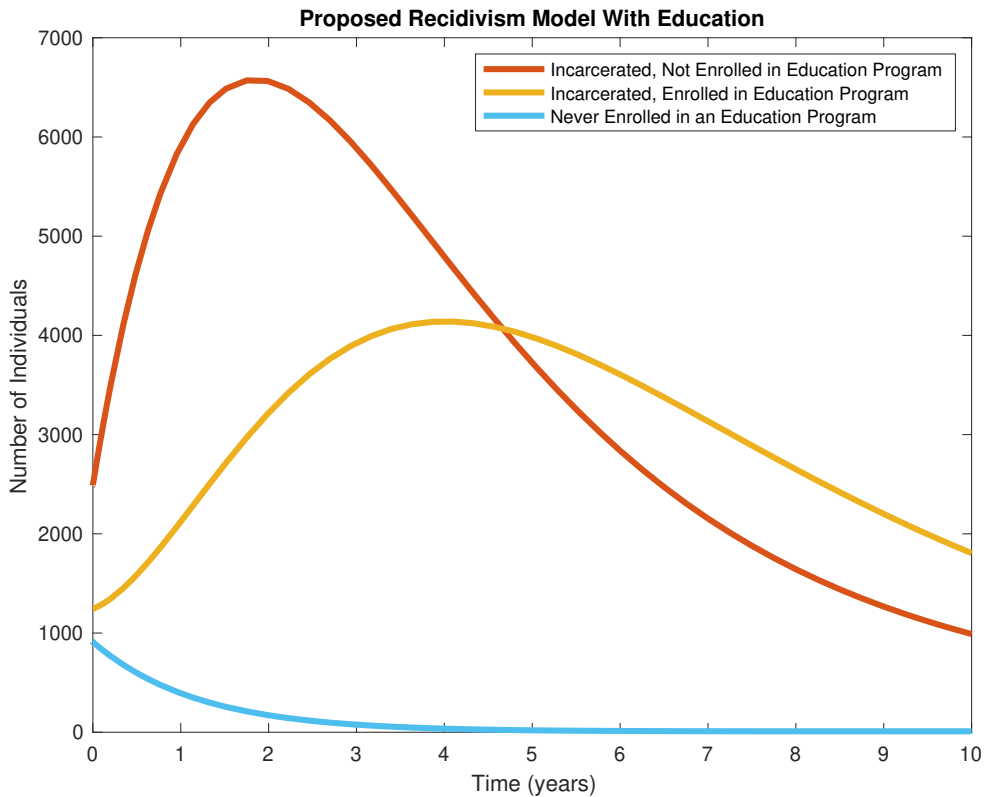

Figure 6: Simulation of Delaware Recidivism: Delaware Implements an Education Program

With the implementation of a higher education program, the number of recidivists decrease by 99.7967%. Also, the incarcerated population decreases by approximately 95%.

3.2.3 California Recidivism

The complete model is founded on and simulated by data from the state of California. This model uses the equations represented in figure 3 and the parameters from table 5. The state of California has numerous higher educational programs available to inmates in prisons within the state, making it an ideal basis for our model with higher educational programs.

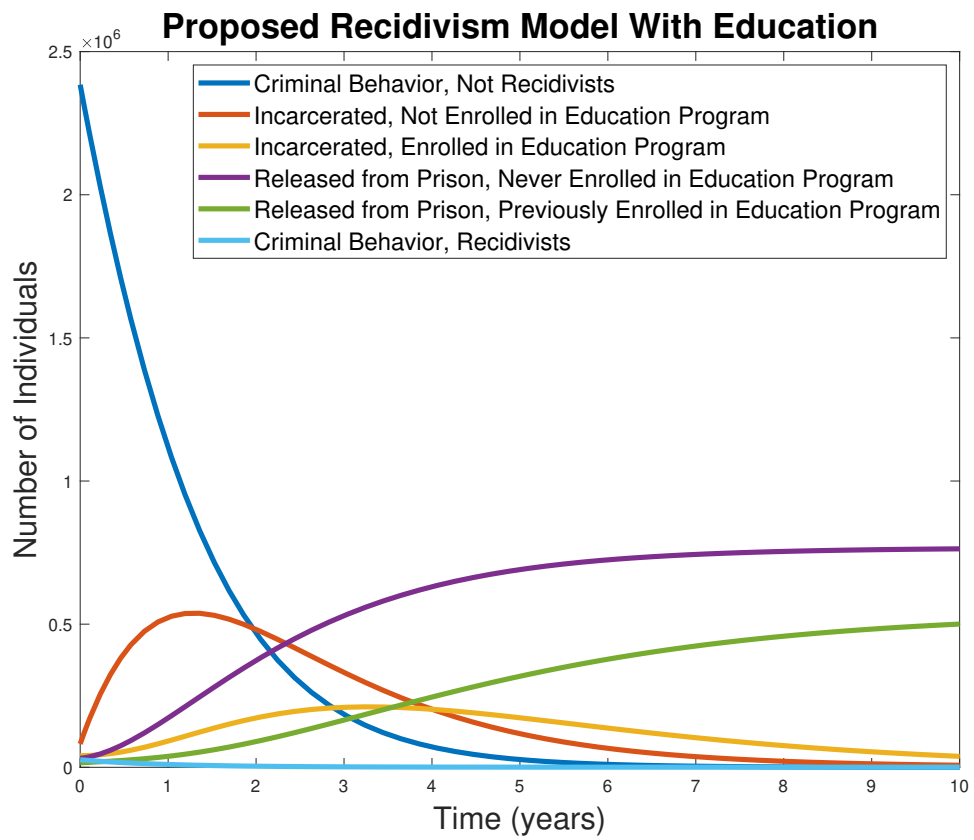

Figure 7: Simulation of California Recidivism

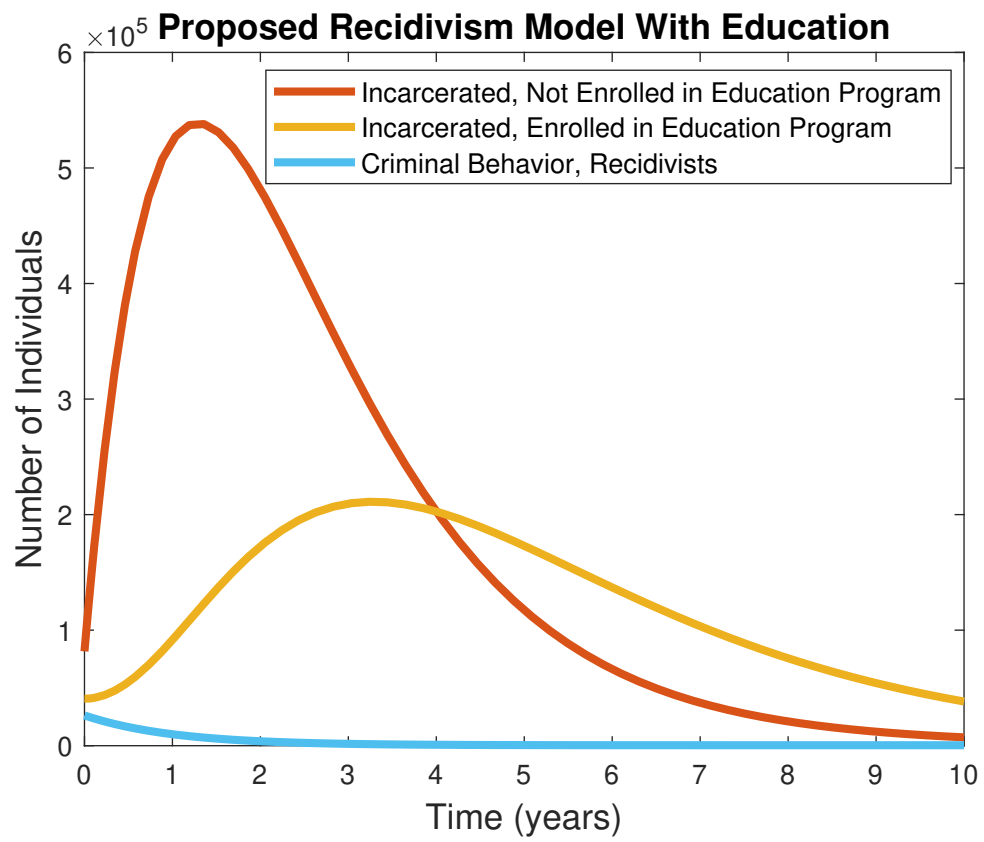

Figure 8: Simulation of California Recidivism

We have chosen to exclude the X_N and X_C class from figure 6 for ease of viewing. As time progresses, the C_1 class decreases rapidly but does not reach zero, meanwhile, the I class increases briefly before also decreasing to a very low number. This reflects a decrease in criminally active non-incarcerated individuals, as incarcerated individuals decrease after a brief increase. From this simulation we can observe that when correctional higher education programs are available, individuals recidivate less often. The proportion of repeat offenders to incarcerated population at the tenth year is $\frac{1609.83}{331357+209497} = 0.00297645945$.

3.2.4 Increased Enrollment in Education Programs

The simulation in figure 7 represents what would happen if California had an increase in recruitment to higher education programs in its prison system. The numerical simulation displays the effect of California's present educational system for the first 3 years, as represented by the solid colored lines. From years 3 to 10, the simulation displays the impact of a 20% increase in the recruitment rate into correctional higher education programs. After 10 years, the number of recidivists in the population is only 521.7. At the final timestamp, the recidivist to incarcerated population ($\frac{C_2}{I_N+I_E}$) is $\frac{521.7}{40250+13540} = 0.009699$.

By comparing the number of recidivising individuals after 10 years we can further quantify the effect of education on recidivism. As stated in section **3.2.3, California Recidivism**, if there are no changes made, there are 1609.83 recidivists and 504,854 incarcerated after 10 years. After a 20% increase in educational recruitment, there are only 521.7 recidivists and 53,790 incarcerated. This is approximately 67% decrease in recidivists and 89% decrease in the number of incarcerated. This simulation demonstrates a clear reduction in recidivism as education recruitment (enrollment) is increased.

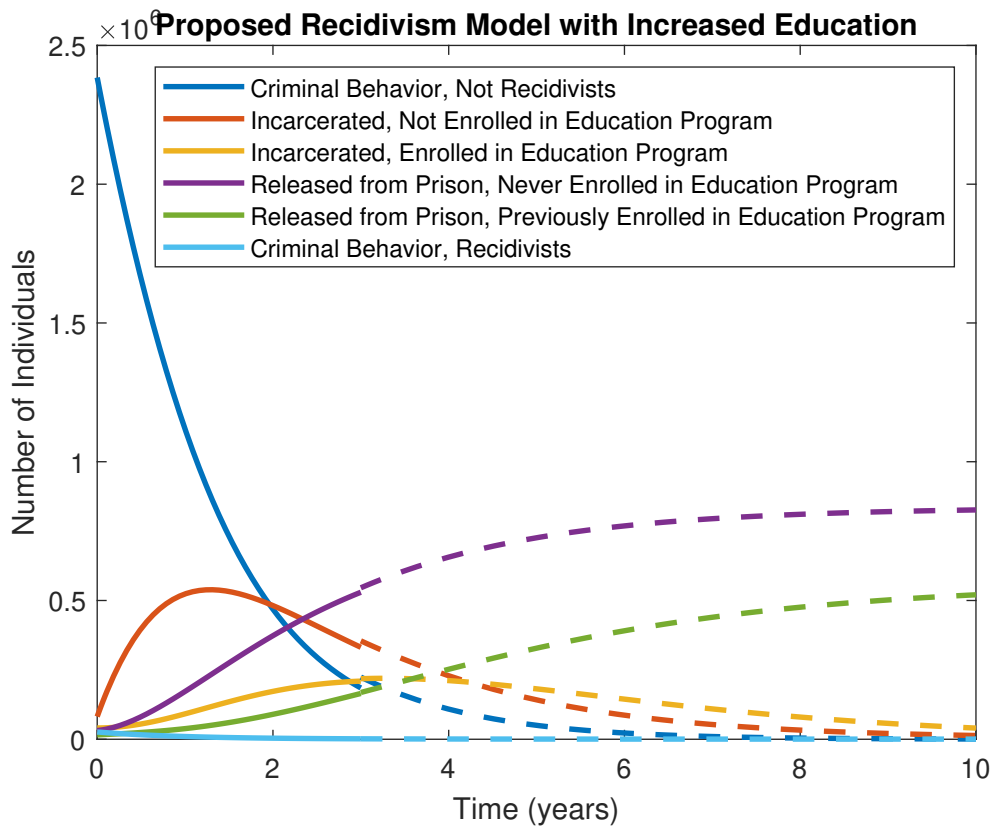

Figure 9: Simulation of California Recidivism: California with Increased Education Recruitment

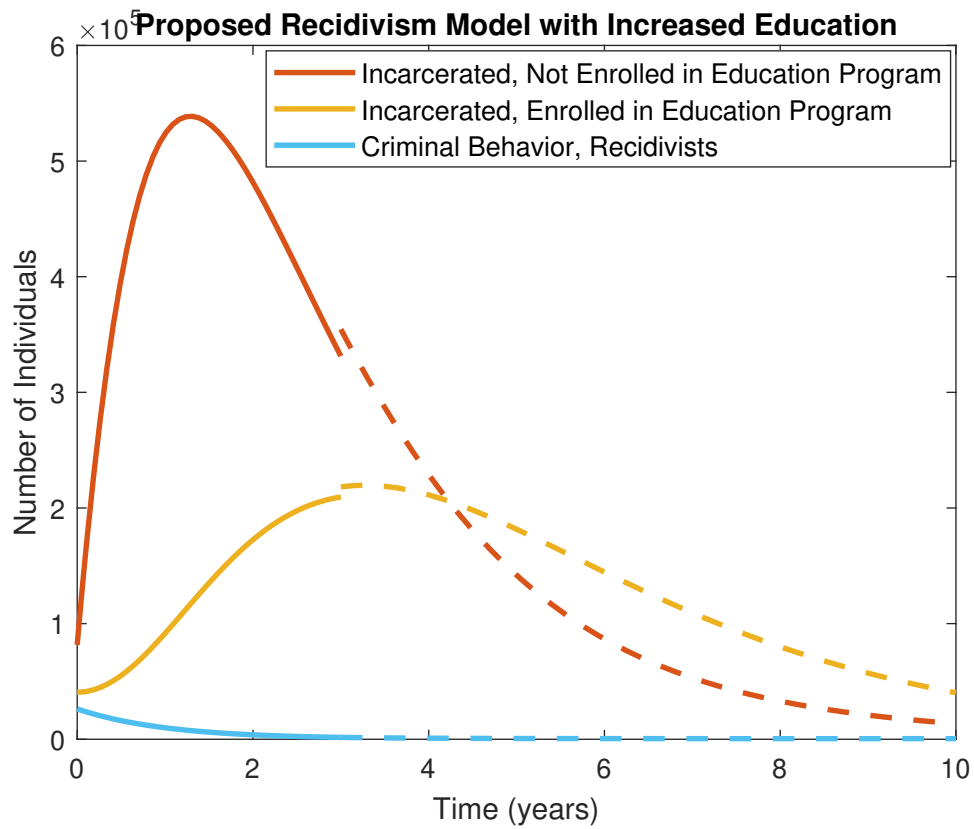

Figure 10: Simulation of California Recidivism: California with Increased Education Recruitment; excluding C_1 , R_E , and R_N classes.

4 Discussion and Conclusions

The simulations performed with the models presented in the paper illustrate the effects of higher education on recidivism. The simulations presented in this paper support the hypothesis that educational programs in prisons reduce recidivism rates.

In Delaware there are few higher educational programs provided in the prison system, and none beyond GED certification. As shown in figure 4, it is visually clear that recidivism will increase over time if nothing is changed. Additionally, this is also clear because the quantity of recidivists increases by 415 individuals; in year 5 there is 2,536 and by year 10 there are 2,951. On the other hand, if Delaware would adopt higher education program in prisons comparable to California, they could have a significant decrease in recidivism rates as seen in figure 5. For the state of Delaware, the recidivist to incarcerated ratios for our baseline model and education model provide insight towards the benefits of education programs. Our baseline model resulted in a recidivist to incarcerated ratio of 0.2368. By implementing education programs similar to California's, the recidivist to incarcerated ratio of Delaware is reduced to 0.0007. This indicates that the addition of higher education programs reduces the amount recidivists.

In California there is around a 33.3% entrance rate into prison higher educational programs [26]. The simulation for California shows that recidivism reduces over time. The simulation for California if higher education programs were all shut down, has a larger $\frac{C_2}{I_N+I_E}$ ratio. Although recidivism does not completely vanish, the recidivist population is small. The education and no education simulations reflect what the social sciences have proposed: education programs in prisons lower recidivism. For the state of California, the recidivist to incarcerated ratio in the education model is 0.00297645945.

Setting all other parameters constant, we were able to simulate various scenarios in the recidivist population by changing our ϕ parameter. For the decreased education scenario that sets $\phi = 0$ after three years of education programs, the recidivist to incarcerated ratio is 0.01050221928. The other scenario which we looked into was a 20% increase in our ϕ parameter after three years, with all other parameters held constant, to simulate an increase in the rate of entrance into education programs. The recidivist to incarcerated ratio for this increased education scenario is 0.009699. It can be seen quantitatively that the elimination of education programs will result in an increased ratio of recidivists to incarcerated prisoners.

Future research should consider modeling the effects of different education programs such as vocational education, adult basic education, and college courses by splitting the I_E compartment into three different compartments to represent each educational program. Further studies should also investigate the implementation of the models presented to other states. This work could also focus on the economic impact of the implementation of education programs in prison systems. It could also expand on the model to include students who un-enroll from an education program and demographic terms in each compartment.

5 Acknowledgements

This research was done at the Quantitative Research for the Life and Social Sciences Program (QRLSSP) REU. We would like to thank Dr. Susan Holechek and Dr. Fabio Milner

for supporting our research through their mentorship and guidance. A special thank you to Dr. Abba Gumel and Dr. Tsafir Mor who provided additional guidance and encouragement towards our project. We would also like to thank Marieke Sorge and Jordy J. Cevallos-Chavez for their expertise throughout this research experience. An additional thank you to associate director of the QRLSSP program, Ms. Sherry Woodley, who helped execute and support this REU program, and to Dr. Tsafir Mor for sharing a pre-print of his book chapter with our group.

References

- [1] ACLU, *Mass Incarceration*, <https://www.aclu.org/issues/smart-justice/mass-incarceration>.
- [2] Brett Dignam, *Learning to Counter Mass Incarceration*, Connecticut Law Review **48** (2016), no. 4, 1217-1230.
- [3] Teresa W. Carns, *Recidivism In Alaska*, Alaska Law Review Online Articles Forum (2008), 1-28.
- [4] Baltazar Espinoza , Christopher M Kribs Alejandra Lopez , Naomi Moreira , Ariana Rivera , Bechir Amdouni, *Economics of Prison: Modeling the Dynamics of Recidivism*, Arizona State University, 2018.
- [5] Mount Tamalpais College, *Our Story*, <https://www.mttamcollege.org/about/our-story/>.
- [6] Wilson E. Alvarez , Itelhomme Fene , Kimberly Gutstein , Brenda Martinez , Diego Chowell , Anuj Mubayi and Luis Melara, *Prisoner Reform Programs, and their Impact on Recidivism*, Arizona State University, 2012.
- [7] Barack Obama, *The President's Role In Advancing Criminal Justice Reform*, The Harvard Law Review Association **130** (2017), no. 3, 832.
- [8] The Sentencing Project, *The Facts: State-by-State Data*.
- [9] David McMillon, Carl P Simon, and Jeffrey Morenoff, *Modeling the Underlying Dynamics of the Spread of Crime*, PLoS ONE **9** (2014), no. 4, 1-22.
- [10] Kristian Lum, Samarth Swarup, Stephen Eubank, and James Hawdon, *The Contagious Nature of Imprisonment: An Agent Based Model to Explain Racial Disparities in Incarceration Rates*, Journal of The Royal Society **11** (2014), no. 9, 1-12.
- [11] John R. Lott and Rujun Wang, *Prisoners in Arizona: A 2017 Update on Selected Topics*, 2018.
- [12] Andrew J. Huenke, *Recidivism in Delaware An Analysis of Offenders Released in 2013 through 2015*, 2019.
- [13] California Department of Corrections and Rehabilitation, *Fiscal Year 2019-2020 Annual Performance Measures Report*, 2020.
- [14] World Population Review, *Recidivism by State*, <https://worldpopulationreview.com/state-rankings/recidivism-rates-by-state>.
- [15] Statistical Analysis Center, Delaware Criminal Justice Council, and State Bureau of Identification, *Crime in Delaware 2015-2019* (2020), <https://sac.delaware.gov/wp-content/uploads/sites/64/2020/08/Crime-in-DE-2019-Master-Report.pdf>.
- [16] Statistical Analysis Center and Delaware Criminal Justice Council, *Recidivism In Delaware An Analysis of Offenders Released in 2013 through 2015* (2019), <https://sac.delaware.gov/wp-content/uploads/sites/64/2019/12/Recidivism2015Final.pdf>.
- [17] United States Sentencing Commission, *Recidivism and the "First Offender"* (2004), https://www.ussc.gov/sites/default/files/pdf/research-and-publications/research-publications/2004/200405_Recidivism_First_Offender.pdf.
- [18] David B. Wilson, Catherine A. Gallagher, and Doris L. Mackenzie, *A Meta-Analysis of Corrections-Based Education, Vocation, and Work Programs for Adult Offenders*, Journal of Research in Crime and Delinquency **37** (2000), no. 4, 347-68.
- [19] Bureau of Justice Statistics, *Time Served in State Prison, 2016* (2018), <https://bjs.ojp.gov/library/publications/time-served-state-prison-2016>.
- [20] National Center for Children in Poverty, *Young Children at Risk: National and State Prevalence of Risk Factors* (2012), <https://www.nccp.org/publication/young-children-at-risk/>.

- [21] Sanne L. A. de Vries , Machteld Hoeve , Mark Assink , Geert Jan J. M. Stams , and Jessica J. Asscher, *Practitioner Review: Effective ingredients of prevention programs for youth at risk of persistent juvenile delinquency – recommendations for clinical practice*, *Journal of Child Psychology and Psychiatry* **56** (2015), no. 2, 108-121.
- [22] United States Census Bureau, *State-to-State Migration Flows* (2019), <https://www.census.gov/data/tables/time-series/demo/geographic-mobility/state-to-state-migration.html>.
- [23] Open Justice Data, *Computational Formulas* (2021), <https://data-openjustice.doj.ca.gov/sites/default/files/stats/2021-06/Comp%20Formulas.pdf>.
- [24] Northwestern Prison Education System, *Benefits of Prison Education*, <https://sites.northwestern.edu/npep/benefits-of-prison-education/>.
- [25] California Innocence Project, *Recidivism Rates*, <https://californiainnocenceproject.org/issues-we-face/recidivism-rates/>.
- [26] US Department of Justice, *Education and Correctional Populations* (2013), <https://bjs.ojp.gov/content/pub/pdf/ecp.pdf>.
- [27] Judy Lin and Andrea Watson, *Education and Correctional Populations* (2020), <https://calmatters.org/explainers/california-population-migration-census-demographics-immigration/>.
- [28] Elizabeth Brown and Mike Males, *Does Age or Poverty Level Best Predict Criminal Arrest and Homicide Rates? A Preliminary Investigation* (2020), http://www.cjcj.org/uploads/cjcj/documents/Does_age.pdf.
- [29] Signe-Mary McKernan, Caroline Ratcliffe, and Stephanie R. Cellin, *Transitioning In and Out of Poverty* (2009), <https://www.urban.org/sites/default/files/publication/30636/411956-Transitioning-In-and-Out-of-Poverty.PDF>.
- [30] United States Census Bureau, *State-to-State Migration Flows* (2019), <https://www.census.gov/data/tables/time-series/demo/geographic-mobility/state-to-state-migration.html>.
- [31] Rob Bonta, California Department of Justice, California Justice Information Services Division, Justice Data Investigative Services Bureau, and Criminal Justice Statistics Center, *Crime in California 2020* (2021), <https://data-openjustice.doj.ca.gov/sites/default/files/2021-06/Crime%20In%20CA%202020.pdf>.
- [32] Lois M. Davis, Robert Bozick, Jennifer L. Steele, Jessica Saunders, and Jeremy N. V. Miles, *Evaluating the Effectiveness of Correctional Education A Meta-Analysis of Programs That Provide Education to Incarcerated Adults*, RAND Corporation (2013), 1-85.
- [33] Alliance for Higher Education in Prison, *National Directory* (2020), <https://www.higheredinprison.org/national-directory/stats-view>.
- [34] Mount Tamalpais College, *Introducing Mount Tamalpais College*, <https://www.mttamcollege.org>.
- [35] Prison Policy Initiative, *Following the Money of Mass Incarceration* (2017), <https://www.prisonpolicy.org/reports/money.html>.
- [36] Tara O'Neill Hayes, *The Economic Costs of the U.S. Criminal Justice System* (2020), <https://www.americanactionforum.org/research/the-economic-costs-of-the-u-s-criminal-justice-system/>.
- [37] Vera Institute of Justice, *Prison spending in 2015* (2017), <https://www.vera.org/publications/price-of-prisons-2015-state-spending-trends/price-of-prisons-2015-state-spending-trends/price-of-prisons-2015-state-spending-trends-prison-spe>