

# Am I Too Fat?: Bulimia as an Epidemic

CORNELL UNIVERSITY, DEPT. OF BIOMETRICS TECHNICAL REPORT BU-1578-M

**Beverly González**  
University Of Illinois at Urbana-Champaign

**Emilia Huerta-Sánchez**  
Mills College-Oakland

**Angela Ortiz-Nieves**  
Universidad Metropolitana-Cupey

**Terannie Vázquez-Alvarez**  
Universidad Metropolitana-Cupey

**Christopher Kribs-Zaleta**  
University of Texas-Arlington

August, 2001

## **Abstract**

For at least the past ten years, eating disorders have had a major impact in the physical and mental health of women, particularly young women. Anorexia and Bulimia nervosa are closely linked eating disorders. Anorexia often precedes bulimia. However, there are about 2 million women in college that have been exclusively bulimic. In this article, we focus on the role of college-peer pressure on the dynamics of anorexia-free bulimia. The model looks at bulimia as a progressive disease and explores the impact of intervention (treatment) at two stages of disease progression. The impact of relapse (a common occurrence among bulimics) is taken into account. Extensions and connections to anorexia are discussed.

# 1 Bulimia Nervosa

Anorexia nervosa, like AIDS, suddenly became widely known to the American public in the mid 1980s. This came about when the popular singer, Karen Carpenter, died of cardiac arrest. Her death which was “associated with the abuse of the over-the-counter drug, Ipecac(used to induce vomiting in cases of accidental poisoning), thrust the shocking, self-destructive aspects of the illness starkly into public consciousness” [8]. In the same decade, a closely related eating disorder came to light, grasping public and professional attention-bulimia nervosa [8]. Now, it has become a huge problem.

## 1.1 Differentiating between Anorexia and Bulimia

Anorexia and Bulimia are very common eating disorders that can sometimes be linked. Instead, they both revolve around the fear of obesity, the pursuit of thinness, and the management between dieting, and biological and behavioral pressure to consume food. The only distinction between the two is the shocking outcome of each [14].

“In anorexia nervosa, this fear is expressed through a number of secondary symptoms including the desire to maintain a suboptimal body weight, body-image disturbance, and food avoidance” [14]. Most anorexics perceive their bodies to be fatter than what it really is, thus inducing a chronic mental state in the individual. Unlike bulimics, this chronic mental state forces the individual into the monotony of eating less and exercising excessively, hence, causing culminating weight loss in the individual [14].

In contrast, bulimic anorexics are not always able to maintain severe dietary restraint. These individuals alternate between a semi-starvation diet that is often times followed by self-induced vomiting, “which can sometimes cause broken blood vessels in the eyes and swollen saliva glands” [2]. Repeated vomiting also “may cause a loss of stomach contents, and since this includes the acid secretions that are needed for digestion, it leads to changes of body chemistry. Major disturbance of the blood chemistry, particularly loss of potassium and rupture of the stomach are occasional causes of sudden death, but fortunately this is rare unless the behavior is extreme” [2]. Acid from the stomach constantly washing over the teeth dissolves the enamel which will cause lasting damage, particularly to the four central upper teeth. In addition to self-induced vomiting, bulimic subtype patients may also abuse the use of laxatives which cause similar distortion of chemistry, and the two behaviors together are most likely to be dangerous [2]. With increasing severity in bulimic disorder, the individuals’ lives become more chaotic. Their lives become so intriguingly chaotic, that it provokes them to scavenge leftovers from a dustbin or steal in order to feed the compulsion [13]. Deeply ashamed of this very act, bulimics tend to do this in secrecy. Unlike anorexia, bulimia is characterized by three subtypes of bulimia which therefore makes it the more complex of the two.

## **1.2 Description of Three Bulimia Nervosa Subtypes**

### **1.2.1 Anorexic Bulimia Nervosa**

Anorexic bulimia nervosa is a variant of the illness that is preceded by a bout of anorexia nervosa. Quite often this anorexic episode is a brief one and the sufferer begins to recover without treatment. It is followed typically by a short period of stabilized weight around 46 kg (approximately 101 lbs.). Because the control of the anorexic is not sustained, bingeing usually begins in a very small way but becomes more severe especially once vomiting begins. Often it begins by vomiting after an ordinary meal, but this leads to a loss of control of the appetite drive, and true bingeing gradually starts. Normally, the vomiting and bingeing start first, but then there is a period of significant weight loss in an anorexic phase that includes restrictive eating. The illness becomes dominated by the bingeing and vomiting behavior, but the weight remains low for a while before gradually rising to near, and in time, normal. The personality profile and backgrounds are similar to those groups with anorexia nervosa. When there are differences, the bulimic group seem to be slightly less obsessive and to be marginally more mature in emotional development [13].

### **1.2.2 Simple Bulimia Nervosa**

Simple bulimia nervosa occurs most frequently at 18 years of age. This is the “closet bulimia,” which means that bulimics do not try to look for treatment. They can stay in this stage for long periods of time without being affected by the usual effects of bulimia. It is usually triggered by a period of unhappiness [13]. This unsatisfactory feeling translates to body dissatisfaction and disgust. Dieting will immediately begin to improve self-esteem, but in contrast to an anorexic, the diet will not be very successful in achieving weight loss. In order to achieve their goal, increased efforts are taken, and so bingeing (the act of eating in excess) and vomiting begin. Control over the body’s normal mechanisms of appetite control is gradually lost, making the eating pattern worse [13]. It is difficult to detect bulimics because they tend to stay at their normal weight. This form of bulimia is the least severe.

### **1.2.3 Multi-Impulsive Bulimia Nervosa**

Multi-impulsive bulimia nervosa, like simple bulimia nervosa, is a severe variant of the latter. It develops the same way as simple bulimia. This group suffers through a range of abnormal behaviors, all of which indicate problems of emotional and impulsive control. Often some of these behaviors are already causing difficulty before the bulimia begins. In association with the eating disorder, other problems including drug abuse, alcohol abuse, deliberate self harm (usually cutting of forearms), stealing and promiscuity. They have a range of backgrounds, but it is quite common to find that there is a high level of disturbance within the family. In personality they are likely to have shown evidence of poor impulse control at an early age, and they often have rather poor records of schooling, academic achievement, or making friends that last. They have a difficulty in modifying their behavior since their actions are

predictable consequences. As a result, helping them to change the pattern of their lives often requires prolonged help. The severity of the illness as with all types of bulimia is varied, and in this group it seems to depend on severity of the underlying abnormality personality [13].

In examining these three subtypes of bulimia, it should be taken into account that there is quite a lot of overlap between them, so that there are a number of sufferers who show characteristics that belong midway between these subgroups[13].

### 1.3 Treatment

Statistics show that without treatment, up to 20 percent of people with serious eating disorders die. With treatment, that number falls to 2-3 percent [1]. About 60 percent of people with eating disorders recover, and in spite of treatment, about 20 percent make only partial recoveries[1]. Because many factors contribute to the development of an eating disorder, and since every individual's situation is different, the "best treatment" must be custom tailored for each individual. An average treatment plan used might include hospitalization to prevent death, suicide, and medical crisis; medication to relieve depression and anxiety; dental work to repair damage and minimize future problems; individual counseling to develop healthy ways of taking control; group counseling to learn how to manage relationships effectively; family counseling to change old patterns and create healthier new ones; nutrition counseling to debunk food myths and design healthy meals; support groups to break down isolation and alienation [2]. Treatment is often along behavioral lines at first and gradually focuses more on emotional problems. For most people medical insurance is necessary due to the high cost of treatment which usually runs between 875 dollars per week[?] up to 23,900 dollars per month for intensive treatment.[11]

## 2 Purpose

Anorexia and Bulimia eating disorders, and their individual effects, are serious eating disorders that bring to light alarming situations. The National Center for Health Statistics estimates that about 9,000 people admitted to hospitals were diagnosed with bulimia in 1994, and about 8,000 were diagnosed with anorexia.[16] Both of these eating disorders seem to have the most impact on young women between the ages of 15-25 in the U.S. It is estimated that eight million people in the U.S. have been diagnosed with having anorexia/bulimia, and out of those eight million people diagnosed with these disorders, seven million of them are females.[12] According to the American Anorexia and Bulimia Association, an estimated 1000 women die of anorexia each year.[16] Because the media portrays thinner models as what our society should look like, "teenagers feel more vulnerable to cultural pressures and develop a milder form of illness in response to such pressures[15]. Bulimia nervosa, has therefore, increased in epidemic proportions since the late 1970s among college-age females.[9] The incidence of bulimia in the college female population, approximately 8 million, has been

estimated to be anywhere from 4 to 20 percent.[9] Early studies indicate that by their first year of college, 4.5 to 18 percent of women have a history of bulimia and that as many as 1 in 100 females between the ages of 12 and 18 have anorexia.[16] Consequently, females are the main target of these eating disorders. Since their practices seem to be very common in the college dormitories, we are only going to incorporate college-age women in our model. Using the fact that bulimia affects about 4 percent of the college female population, our population is going to be centered around 4 percent of the total college female population. Also, realizing that many factors contribute to a female becoming bulimic, we are assuming that the average time that a female stays in that college is three years (this might be due to a transfer, death in the family, drops out,..etc.). Peer-pressure will be the reason of infection by her bulimic friends. Once bulimic, these females can go from the beginning stages of bulimia to the advanced stages of bulimia. We then make the big assumption that friends and family both play a role in peer-pressuring these people into getting treatment. Assuming these individuals get treated, they can either go into relapse to the multi-impulsive bulimia (like alcoholism, these people will feel the effects twice as much if they go back to it) or realistically attain total recovery. However, due to the time-frame needed to get recovered, we are not going to even consider this. The average time for treatment is usually 3-10 years depending on the severity of the disorder, and our model only considers 3 years in college. Even though statistics show that bulimia has risen dramatically, the amount of public concern does not seem to have a similar reaction. The purpose of this research on bulimia is to produce good results. Results that will have a positive impact on the current status of bulimia. If we treat bulimia as an epidemic, we would like to observe the possible factors that might make a difference. For example, what rate has most significance in the model, and how efficient is the treatment. The possible ways that we can reduce/increase the most sensitive parameter. If factors like education can be used to reduce the rate of infection we are also interested to know if treatment is effective the way it is currently placed (after  $B_2$ ). If not, then maybe discuss the possibility of making changes to stop the epidemic from spreading.

### 3 The Deterministic Model

#### 3.1 The Model

We have a model that illustrates the relation between anorexia and bulimia. In creating this model we found that it was very complex. We have a susceptible class of 12-22 aged females represented by omega. In this model, we consider anorexia and bulimia. A susceptible individual has the choice of becoming anorexic and bulimic. Once anorexic there is a 50% chance [12] and [7] that the individual will become bulimic. There is treatment available specifically for bulimics or treatment for anorexics. From treatment, the infected people can have relapses or they can recover. Notice that if we set the parameters  $A = 0$  and  $T = 0$ , we have a model just for bulimia. The model is represented by the diagram in Figure 1:

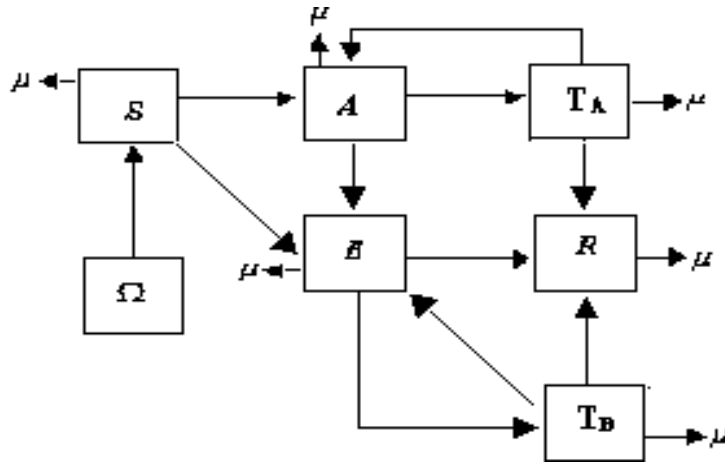

Figure 1: Anorexia and Bulimia Model

We concentrate on bulimia. As opposed to our first model, this model considers education, the two stages of simple bulimia, and a recovered class. It also incorporates specific treatments for the two stages of simple bulimia. Our goal here is to see if there is a dramatic change if the susceptible class gets educated about bulimia before-hand, as opposed to those susceptibles that do not get educated about bulimia before-hand. Where **E** denotes education, **S** denotes the susceptible class, **T<sub>1</sub>** denotes treatment for simple bulimia( $B_1$ ), **T<sub>2</sub>** denotes treatment for the advanced simple bulimia( $B_2$ ), and **R** denotes the recovered class. A more detailed bulimia model is represented by the diagram in Figure 2:

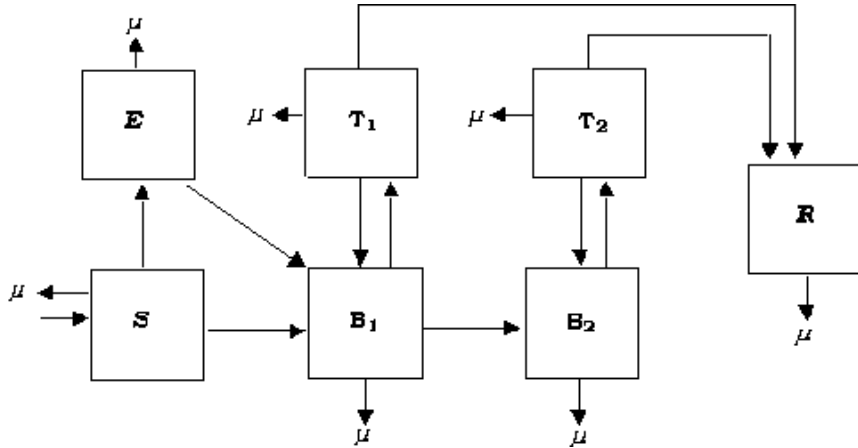

Figure 2: Bulimia Model

The susceptible individuals are represented by  $S$  (college-female students). State  $B_1$  and  $B_2$  represent individuals infected with simple bulimia ( $B_1$ ) and advance simple bulimia nervosa ( $B_2$ ). State  $T$  consists of individuals in treatment undergoing medical, psychological and nutritional treatment. We use  $P = S + B_1 + B_2 + T$  to represent the total constant population. The individuals in state  $B_1$  are closet bulimics, who are not receiving treatment. They are not receiving treatment, they are ashamed of their problem. When episodes of bingeing and purging occur with more frequency, they move to state  $B_2$ , the advanced state. At this state, it is critical that the bulimic individual seeks medical attention, otherwise it can be very dangerous. Consequently, the individuals who are in  $B_2$  move to treatment category at a rate that depends on pressure from parents ( $\rho$ ) and pressure from people who are currently receiving treatment ( $\delta$ ). In  $T$ , individuals are treated with the same medication but due to the nature of ( $B_2$ ) bulimia, this treatment will be slow depending on the history of the bingeing and purging in the individual. There are many who relapse and go back to state  $B_2$ . The model is represented by the following diagram:

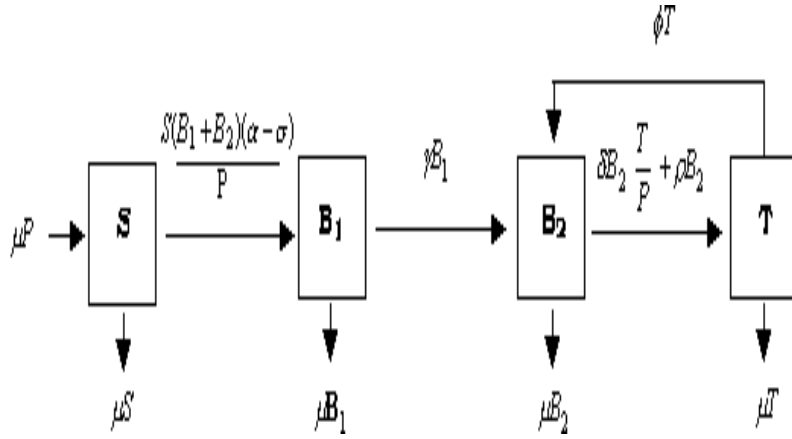

Figure 3: Reduced bulimia model

Where,  $P = S + B_1 + B_2 + T$

$P$  = Total population

$S$  = Susceptible individuals

$B_1$  = Individuals infected with Simple Bulimia Nervosa

$B_2$  = Individuals infected with a more severe case of  $B_1$

$T$  = Infected individuals that are in treatment

Table 1: Parameter List

Parameters	Description
$\mu$	Rate of mortality
$\alpha$	Rate at which people develop $B_1$
$\gamma$	Rate at which people infected with $B_1$ develop $B_2$
$\delta$	Rate at which people infected with $B_2$ get treatment due to people currently in treatment
$\rho$	Rate at which people infected with $B_2$ get treatment due to needed medical care or families
$\phi$	Rate at which people in treatment return to $B_2$
$\sigma$	Amount by which education reduces the rate at which people become bulimic $B_1$



## 3.2 The Model and Its Assumptions

Recovery was eliminated because  $\mu$  is big enough that people age out before they get to recovery. Treatment for  $B_1$  was eliminated because normally people in  $B_1$  do not seek treatment. In order to reduce complexity, the effects of education are modeled a reduction in the value of  $A$ . The model only accounts for women in college in a period of three years. We assume that the population is constant. Susceptibles become bulimics due to peer pressure. Therefore, the rate at which susceptible women develop bulimia depends on how much interaction a woman has with her bulimic friends. There are two stages of bulimia, and at its first stage it is very rare that women will look for treatment. If these women do not get treatment then it is imminent that they will enter the second, more dangerous state of simple bulimia nervosa. While women are in this stage it is critical that they have treatment. We assume that they are either going to treatment because of pressure from women that are already getting treated or because they are so sick that they need medical help. Bulimia is like alcoholism in that people with the disease can drop out of treatment or have relapses after they have recovered, hence relapse is included.

## 3.3 The System of Equations

The system of differential equations consists of five equations that can be reduced to four (since the population is constant):

$$\begin{aligned}\frac{dS}{dt} &= \mu P - \frac{(\alpha - \sigma)S(B_1 + B_2)}{P} - \mu S \\ \frac{dB_1}{dt} &= \frac{(\alpha - \sigma)S(B_1 + B_2)}{P} - \gamma B_1 - \mu B_1 \\ \frac{dB_2}{dt} &= \gamma B_1 - \mu B_2 - \delta B_2 \frac{T}{P} - \rho B_2 + \phi T \\ \frac{dT}{dt} &= \delta B_2 \frac{T}{P} + \rho B_2 - \mu T - \phi T\end{aligned}$$

$$\text{where } P = S + B_1 + B_2 + T.$$

We rescaled the equations with the dimensionless variables,  $x = \frac{S}{P}$ ,  $y_1 = \frac{B_1}{P}$ ,  $y_2 = \frac{B_2}{P}$ , and  $z = \frac{T}{P}$ , so that the equations can be rescaled to

$$\frac{dx}{dt} = \mu - (\alpha - \sigma)(y_1 + y_2) - \mu x \quad (1)$$

$$\frac{dy_1}{dt} = (\alpha - \sigma)(y_1 + y_2) - \mu y_1 - \gamma y_1 \quad (2)$$

$$\frac{dy_2}{dt} = \gamma y_1 - \mu y_2 - \delta y_2 z - \rho y_2 + \phi z \quad (3)$$

$$\frac{dz}{dt} = \delta y_2 z + \rho y_2 - \phi z - \mu z \quad (4)$$

$$\text{where } 1 = x + y_1 + y_2 + z. \quad (5)$$

$A = \alpha - \sigma$  is the net infective force including the amount by which education reduces the rate at which people become bulimic.

## 4 $R_0$ and the Equilibrium Points

### 4.1 The Bulimia-Free Equilibrium

Since we know that  $x + y_1 + y_2 + z = 1$ , we are able to find the disease-free equilibrium. If there is no disease, then  $y_1, y_2$ , and  $z$  are zero. If that's true then  $x = 1$ . Thus it is easy to deduce that the bulimia-free equilibrium is equal to  $[1, 0, 0, 0]$ . We used Lyapunov method to solve for stability. If there is a function  $V$  such that  $V(\vec{x}) > 0$  for  $\vec{x} \neq x^*$ ,  $V(\vec{x}^*) = 0$  and

$$\frac{dV}{dt} < 0$$

for  $\vec{x} \neq x^*$ , then  $\vec{x} = x^*$  is globally stable.

Now here, let  $V = y_1 + y_2 + z$ .

$$\begin{aligned} \frac{dV}{dt} &= Ax(y_1 + y_2) - \mu(y_1 + y_2 + z) \\ &< A(y_1 + y_2) - \mu(y_1 + y_2), (x < 1) \\ &(A - \mu) - (y_1 + y_2) < 0 \end{aligned}$$

if  $A < \mu$ . So **Theorem.** The bulimia-free equilibrium  $(1, 0, 0, 0)$  is globally stable if  $A < \mu$ .

### 4.2 The Basic Reproductive Number $R_0$

The  $R_0$  is the average number of secondary cases caused by an infected individual. To calculate it, we used the method given in Diekmann et al[6] and Castillo-Chavez et al[7]. Here we took  $y_1$  and  $y_2$  as the infective classes and  $x$  as the susceptible class. We used  $z$  to find the disease-free equilibrium.

Let  $U_0 = (X^*, 0, 0)$  denote the disease free equilibrium. We need to solve for  $z$  in equation (4) and substitute it in equation (3) to put  $\frac{dy_2}{dt}$  in terms of  $y_1$  and  $y_2$ . Then we took the Jacobian of  $y_1, y_2$  and evaluated it at  $U_0$ :

$$J(X^*, 0, 0) = \begin{bmatrix} -\gamma - \mu + A & A \\ \gamma & \frac{\phi\rho}{\mu+\phi} - \rho - \mu \end{bmatrix}$$

Thus, we write  $J$  in the form  $J = M - D$ , with  $M > 0$  and  $D > 0$ . Then we found the  $MD^{-1}$  which is

$$MD^{-1} = \begin{bmatrix} \frac{A}{\mu+\gamma} & \frac{A}{\mu+\rho} \\ \frac{\gamma}{\gamma+\mu} & \frac{\phi\rho}{(\mu+\phi)(\rho+\mu)} \end{bmatrix}$$

$R_0$  is the dominant eigenvalue of  $MD^{-1}$ , namely

$$R_0 = \frac{1}{2} \left[ \frac{A}{\mu+\gamma} + \frac{\phi\rho}{(\phi+\mu)(\mu+\rho)} + \sqrt{\left( \frac{A}{\mu+\gamma} - \frac{\phi\rho}{(\phi+\mu)(\mu+\rho)} \right)^2 + \frac{4\gamma A}{(\mu+\rho)(\mu+\gamma)}} \right]$$

### 4.3 Interpreting $R_0$

As we suspected,  $R_0$  is a function of  $A$ . Interpreting  $R_0$  is complicated, but it can be done in the following way. We can say that

$$R_0 < \frac{A}{\mu+\gamma} + \sqrt{\left( \frac{A}{\mu+\gamma} - \frac{\gamma}{\mu+\rho} \right)} \quad (6)$$

Note:  $\phi$  and  $\delta$  do not appear because initially nobody is being treated so  $\delta$ 's coefficient is 0. Hence,  $\phi$  also disappears. Now let

$$R_0(S \longrightarrow B_1) = \frac{A}{\mu+\gamma} = R_0(B_1) \quad (7)$$

Expression (7) represents how many susceptibles a single  $B_1$  "infects" per year. The expression under the radical in (6) expresses the number of susceptibles infected by one  $B_2$ , multiplied by the number of  $B_1$ 's who progress to  $B_2$  before an average  $B_2$  individual leaves: if

$$R_0(B_1 \longrightarrow B_2) = \frac{\gamma}{\mu+\rho},$$

then we have,

$$\sqrt{R_0(S \longrightarrow B_1)R_0(B_1 \longrightarrow B_2)} = R_0(B_2)$$

The reason why a radical is part of the  $R_0$  is linked to the nature of our model. In our model, the only way to get treatment is by passing through  $B_2$ . Thus, individuals infected with  $B_1$  need to do a 2-step process in order to be treated. This 2-step is related to the next-generation idea [3]  $R_0 < R_0(B_1) + (B_2)$  because there is an overlap between the two sets of infected individuals, via  $R_0(S \longrightarrow B_1)$ . Even though  $\delta$  does not appear in  $R_0$ , we suspect that  $\delta$  will influence how many endemic equilibria there are. It is a function of  $A$  as it should be, and if  $A$  ("negative" peer pressure rate) increases then  $R_0$  will increase. Hence, from all the parameters  $(A, \rho, \gamma, \phi, \mu)$   $A$  is the most influential.

## 4.4 The Endemic Equilibrium

The existence of endemic equilibria is difficult to establish as the following analysis shows.

### Proposition 1

If  $R_0 > 1$ , we have either one or three endemic equilibria.

**Proof.** If  $R_0 < 1$ , we have zero or two endemic equilibrium points.

We reduced the system of equations (1 – 5) into just one equation by expressing  $x, y_1, y_2, z$  in terms of  $y_2$ . In this case,  $x, y_1, y_2$ , and  $z$  are

$$x = \frac{\mu}{\mu + Ay_2\left[1 + \frac{\mu}{\gamma}\left(1 + \frac{\rho}{\mu + \phi - \delta y_2}\right)\right]} \quad (8)$$

$$y_1 = y_2 \frac{\mu}{\gamma} \left(1 + \frac{\rho}{\mu + \phi - \delta y_2}\right) \quad (9)$$

$$z = y_2 \frac{\rho}{\mu + \phi - \delta y_2} \quad (10)$$

When we add them together to set,

$$1 = \frac{\mu}{\mu + Ay_2\left[1 + \frac{\mu}{\gamma}\left(1 + \frac{\rho}{\mu + \phi - \delta y_2}\right)\right]} + y_2 \left[\frac{\mu}{\gamma} \left(1 + \frac{\rho}{\mu + \phi - \delta y_2}\right) + 1 + \frac{\rho}{\mu + \phi - \delta y_2}\right]$$

After dividing by  $y_2$ , we will have an equation

$$f(y_2) = By_2^3 + Cy_2^2 + Dy_2 + E = 0 \quad (11)$$

where  $f(0) = E < 0$  iff  $R_0 > 1$ , and

$$f(0) < 0 \iff A > \frac{\mu(\mu + \gamma)(\mu + \rho + \phi)}{(\mu + \gamma)(\mu + \rho + \phi) - \rho\gamma} \iff R_0 > 1$$

Now, for an endemic equilibrium we need  $x^*, y_1^*, y_2^*, z^* \geq 0$ , and that they add up to 1. From Equation (5) we already know that they add up to one, since we used that to find  $f(y_2)$ , and that

$$z^* = \frac{\rho y_2^*}{\mu + \phi - \delta y_2^*}.$$

So, for  $y_2^* > 0$ , we need  $\mu + \phi - \delta y_2^* > 0$  in order for  $z^* > 0$ . Therefore, we assume that

$$y_2^* < \frac{\mu + \phi}{\delta}.$$

With this condition, we can see that

$$y_1^* = y_2^* \frac{\mu}{\gamma} \left(1 + \frac{\rho}{\mu + \phi - \delta y_2^*}\right) > 0,$$

and

$$x^* = \frac{\mu}{\mu + A(y_1^* + y_2^*)} > 0$$

are positive. Hence, endemic equilibria are solutions to  $f(y_2) = 0$ ,  $y_2^* \in (0, \frac{\mu+\phi}{\delta})$ . It is not necessary to worry about whether  $\frac{\mu+\phi}{\delta} > 1$  or  $\frac{\mu+\phi}{\delta} < 1$  since equation(5) already guarantees solutions less than 1. Now, let's consider  $f(0)$  and  $f(\frac{\mu+\phi}{\delta})$ . We already know what  $f(0)$  is equal to:

$$f(0) < 0 \iff A > \frac{\mu(\mu + \gamma)(\mu + \rho + \phi)}{(\mu + \gamma)(\mu + \rho + \phi) - \rho\gamma} \iff R_0 > 1$$

and

$$f\left(\frac{\mu + \phi}{\delta}\right) = \left(\frac{\mu + \phi}{\delta}\right)\left(\frac{\mu + \phi}{\gamma}\right)\frac{\mu}{\gamma}A\rho^2 > 0.$$

This means that there are two conclusions that we can draw from this. If  $R_0 > 1$ , we have either one or three endemic equilibria. If  $R_0 < 1$ , we have zero or two endemic equilibrium points  $\square$

## 5 Possible Endemic Equilibria

### 5.1 The Bifurcation at $R_0 = 1$

For all of our numerical examples, we always get a forward bifurcation graph when  $R_0 > 1$ .

We suspect that there might be a backward bifurcation graph, but it is difficult to find out whether that actually happens. In order to have a backward bifurcation graph we need to have  $f'(0) < 0$  Now, when we take the derivative of  $f$  and evaluate it at zero, we get

$$\begin{aligned} f'(0) = \delta \left[ \frac{\mu + \gamma}{\gamma} (2(\mu + \phi) + \rho)(A - \mu) - A\rho \right] \\ + \left[ \left(\frac{\mu + \gamma}{\gamma}\right)^2 (\mu + \phi + \rho)^2 A - A\left(\frac{\mu + \gamma}{\gamma}\right)(\mu + \phi + \rho) \right] \end{aligned} \quad (12)$$

So, we can say that  $f(0)$  is expressed in the form

$$f'(0) = K_1\delta + K_2, K_2 > 0$$

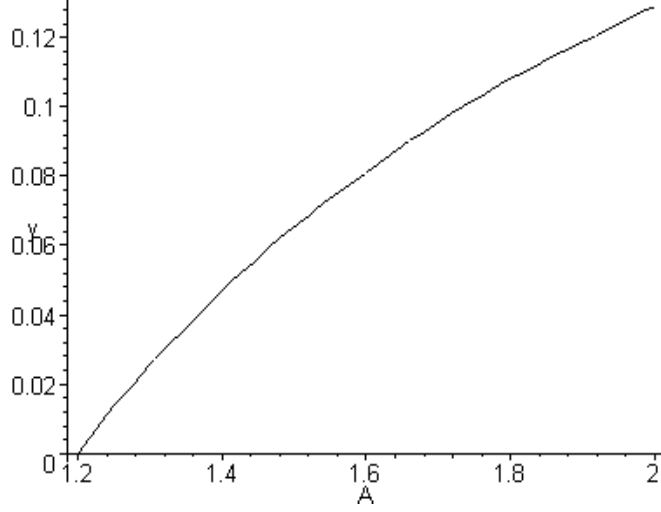

Figure 4: Numerical example of bifurcation graph

Since  $K_2 > 0$ , then the only way  $f'(0) < 0$  is if  $K_1 < 0$  because  $\delta$  cannot be negative. So, if  $K_1 > 0$ , then there is no backward bifurcation. If  $K_1 < 0$ , then there is a backward bifurcation graph, for  $\delta > -\frac{K_2}{K_1}$ . From equation (12) we know that

$$K_1 = A \left[ 2\frac{\mu + \gamma}{\gamma}(\mu + \phi) + \frac{\mu}{\gamma}\rho \right] - \mu \left[ 2\frac{\mu + \gamma}{\gamma}(\mu + \phi) + \frac{\mu + \gamma}{\gamma}\rho \right]$$

and if we simplify for  $A$  we get,

$$K_1 < 0 \iff A < \mu \frac{2\left(\frac{\mu + \gamma}{\gamma}\right)(\mu + \phi) + \left(\frac{\mu + \gamma}{\gamma}\right)\rho}{2\left(\frac{\mu + \gamma}{\gamma}\right)(\mu + \phi) + \frac{\mu}{\gamma}\rho} \quad (13)$$

$$= \mu \frac{2(\mu + \phi) + \rho}{2(\mu + \phi) + \frac{\mu}{\mu + \gamma}\rho} \equiv \mu k_1,$$

Now note  $R_0 < 1 \iff A < \mu \frac{(\mu + \phi) + \rho}{(\mu + \phi) + \frac{\mu}{\mu + \gamma}\rho} \equiv \mu k_2$ . Since

$$k_1 = 1 + \frac{\gamma}{\mu + \gamma} \frac{\rho}{2(\mu + \phi) + \frac{\mu}{\mu + \gamma}\rho} < 1 + \frac{\gamma}{\mu + \gamma} \frac{\rho}{(\mu + \phi) + \frac{\mu}{\mu + \gamma}\rho} = k_2$$

We see that

$$A < \mu k_1 \Rightarrow A < \mu k_2 \Rightarrow R_0 < 1.$$

Thus, at  $R_0 = 1$  (or sufficiently close to 1),  $A > \mu k_1$ , so  $f'(0) > 0$ , and we conclude that we have no backward bifurcation graph at  $R_0 = 1$ . However, it is still possible to have endemic equilibria with  $R_0 < 1$  if the following occurs: A bifurcation where the graph starts going forward from  $R_0 = 1$ , turns back after some time, and then it turns again and goes forward again.

## 5.2 Special Cases in $\delta$

Since we are interested in the effects of peer pressure, we now consider two special cases in  $\delta$ , which we recall is independent of  $R_0$ .

If we consider the case  $\delta = 0$ , we find that  $B = C = 0$  in (11). This makes the endemic equilibrium condition linear. Therefore if  $\delta = 0$ , there is never more than one endemic equilibrium. Our other special case is the opposite extreme when everybody in  $B_2$  gets treated. When  $\delta$  is close to  $\infty$ . Can we have a delta big enough to have a backward bifurcation? Consider the part of  $f(y_2)$  which has  $\delta^2$ ,

$$f(y_2) = \delta^2 \left[ \left( \frac{\mu + \gamma}{\gamma} \right)^2 A y_2^3 + \left( \frac{\mu + \gamma}{\gamma} \right) (\mu - A) y_2^2 \right] + \dots$$

If  $\delta$  is very big then this part must be zero at an endemic equilibrium  $y_2^*$ . This means either

$$(y_2^*)^2 = \mathcal{O}\left(\frac{1}{\delta}\right)$$

or

$$\left( \frac{\mu + \gamma}{\gamma} \right) A y_2^* + (\mu - A) = \mathcal{O}\left(\frac{1}{\delta}\right)$$

i.e.,

$$y_2^* = \frac{A - \mu}{A} \frac{\gamma}{\mu + \gamma} + \mathcal{O}\left(\frac{1}{\delta}\right) \approx \frac{A - \mu}{A} \frac{\gamma}{\mu + \gamma}$$

Suppose  $R_0$  is big enough (not necessarily  $> 1$ ) that  $A > \mu$ . Then this

$$y_2^* = \frac{A - \mu}{A} \frac{\gamma}{\mu + \gamma} > 0$$

In fact, it is presumably bigger than  $\frac{\mu + \phi}{\delta}$ , since  $\frac{1}{\delta}$  is small. Thus, we have three points where we know  $f$ :  $0$ ,  $\frac{\mu + \phi}{\delta}$ , and  $y_2^*$ . Furthermore, we can show  $f'(y_2^*) > 0$ . Now, since we also know that  $f(y_2) \rightarrow -\infty$  as  $y_2 \rightarrow -\infty$  and  $f(y_2) \rightarrow \infty$  as  $y_2 \rightarrow \infty$ , we can establish where the zeroes of  $f$  must lie. If  $R_0 < 1$ , we have  $f(0) > 0$ ,  $f\left(\frac{\mu + \phi}{\delta}\right) > 0$ ,  $f(y_2^*) \approx 0$ ,  $f'(y_2^*) > 0$ , so there must be a zero crossing to the left of  $0$ , another one between  $f\left(\frac{\mu + \phi}{\delta}\right)$  and  $y_2^*$  (since  $f'(y_2^*) > 0$ ), and the third near  $y_2^*$ . If  $R_0 > 1$ , we have  $f(0) < 0$ ,  $f\left(\frac{\mu + \phi}{\delta}\right) > 0$ ,  $f(y_2^*) \approx 0$ ,  $f'(y_2^*) > 0$ , and the only change is that the first zero crossing must be in  $(0, \frac{\mu + \phi}{\delta})$ , as promised by Proposition 1. In neither case is there an extra pair of endemic equilibria. Thus, if any ever exists, they must do so for intermediate values of  $\delta$ .

## 6 Deterministic Simulations

We simulate in proportion vs. time the existence and evolution of the simple bulimia ( $B_1$ ) and advanced bulimia ( $B_2$ ), using a Matlab program [Appendix 11.1], to test the efficacy of different parameters. We are going to focus on the effect of increasing or decreasing the peer pressure parameter and test the application of treatment in the

$B_1$  and  $B_2$  classes.

In calculating the mortality rate,  $\mu$ , we take into consideration the maximum time an individual stays in the system which is three years. Therefore,  $3 = \frac{1}{\mu}$ , making  $\mu = \frac{1}{3}$ . The rate of going from  $B_1$  to  $B_2$ , was assumed to be between 1 and 2. We assumed that it takes between half a year and one year to pass to the more advanced stage of bulimia ( $B_2$ ). Likewise, in calculating the relapse rate,  $\phi$ , we used supporting data from the article: Rate and prediction of Relapse in Bulimia Nervosa [10], that say that the relapse rate is .01. Many of the parameters ( $\alpha, \rho, \delta$ ) depend on peer pressure; there is not a set way to measure peer pressure. These can range from  $(0, \infty)$ . We calculated the value of  $\rho$  using the  $R_0$ ; using the parameters of the other values and a value for  $R_0$ , we calculated a value for  $\rho$ . Using the fact that bulimia nervosa affects 4 percent of the total female college population, we know that  $B_1$  and  $B_2$  together make up this 4 percent. In our system, it makes sense to say that  $B_1 > B_2$ , given the fact that initial condition of  $B_2 = 0$ , our  $B_1$  is estimated to be anywhere between  $[0, .04]$ . The initial condition for the treatment is 0 and for the susceptible class is  $1 - (B_1 + B_2)$ .

The results obtained from running simulations coincide with our expectations. As the value of  $A$  increase we are going to have more bulimic people (see Figures 5 and 6). We can say that the spread of the disease depends on the peer pressure that the susceptible people receive. If we increase the value of  $\rho$  we obtain more people in treatment (see Figure 7) and if we decrease it there are fewer people in treatment (see Figure 8). We can say that the amount of people that go to treatment depends too on the peer pressure. To illustrate what would happen if treatment was given to the people in  $B_1$ , we are going to vary the value of  $\gamma$ . If  $B_2$  decreases, it would be a projection of what would happen if some individuals in  $B_1$  recovered. That would correspond with a decrease in  $\gamma$  because if people were being treated than the rate ( $\gamma$ ) at which they were moving to  $B_2$  would decrease. When we increase  $\gamma$ , the number of people in  $B_2$  increases (see Figure 9) and when we decrease  $\gamma$ ,  $B_2$  decreases (see Figure 10). Thus if treatment was given in  $B_1$ , it would be more effective because it is easier to control the disease at an earlier stage.



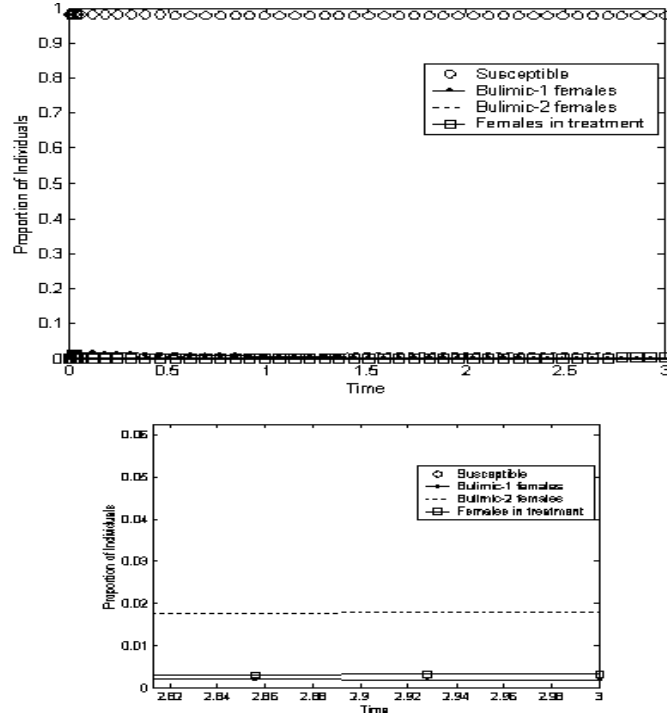

Figure 5: Parameter values:  $\mu=.33$ ,  $\phi=.01$ ,  $\rho=.083$ ,  $\delta=.3$ ,  $\gamma=1.5$ ,  $A=.5$ ,  $B_1=.02$ ,  $B_2=0$  and  $R_0= 1.19$ . In this graph above we can see that the value of  $A$  is very small. The number of susceptibles is almost 1 and the number of bulimics is small too. This is due to the value given to  $A$ , and the value of  $R_0$ . Note: The  $R_0$  is not much bigger than 1, so de endemic level is low.

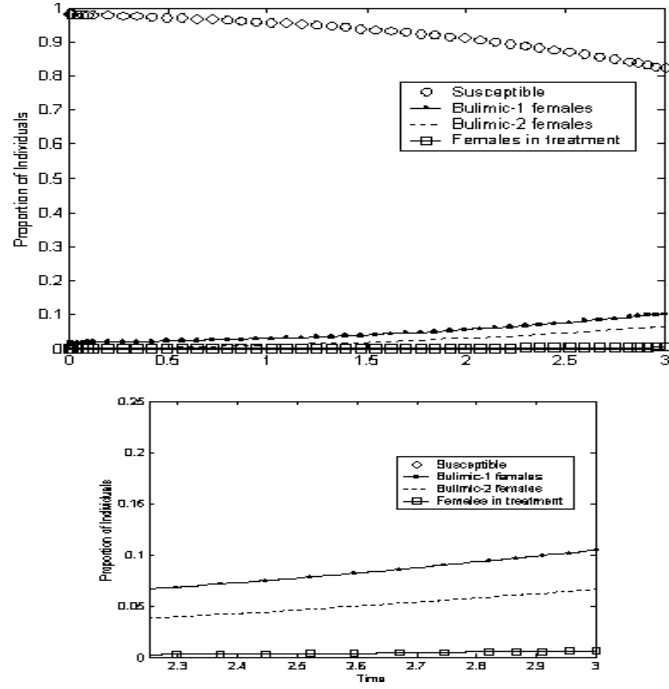

Figure 6: Parameter values:  $\mu=.33$ ,  $\phi=.01$ ,  $\rho=.083$ ,  $\delta=.3$ ,  $\gamma=1.5$ ,  $A=.8$ ,  $B_1=.02$ ,  $B_2=0$  and  $R_0=1.499$ . In the graph above we increase the value of  $A$  and compare it with Figure 5. We can see that the number of susceptibles is dropping faster and the number of bulimics is growing. Note: Here the endemic level is higher as  $R_0$  is higher.

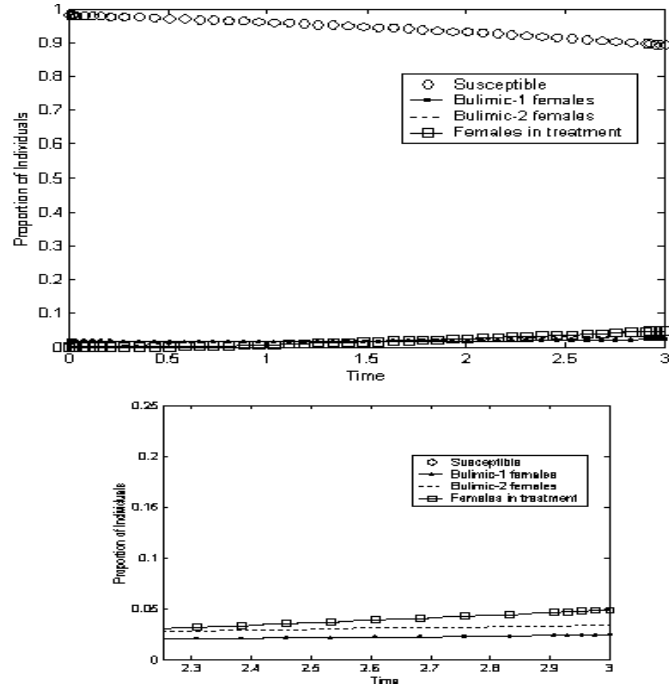

Figure 7: Parameter values:  $\mu=.33$ ,  $\phi=.01$ ,  $\rho=.8$ ,  $\delta=.3$ ,  $\gamma=1.5$ ,  $A=.8$ ,  $B_1=.02$ ,  $B_2=0$  and  $R_0=1.019$ . In this graph above we see that if we increase the value of  $\rho$  and compare with Figure 6, we can see the number of people in treatment is growing. Therefore, treatment is a good idea.

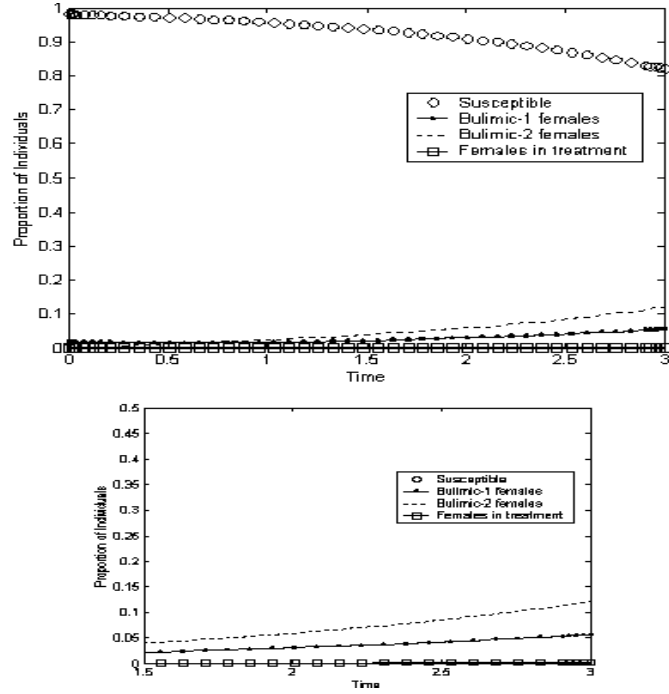

Figure 8: Parameter values:  $\mu=.33$ ,  $\phi=.01$ ,  $\rho=.02$ ,  $\delta=.3$ ,  $\gamma=1.5$ ,  $A=.8$ ,  $B_1=.02$  and  $R_0=1.605$ . In this graph we see that if we decrease the value of  $\rho$  and if we compare it with the figure 7, we are going to have fewer people in treatment. The disease prevalence rises because treatment is not given.

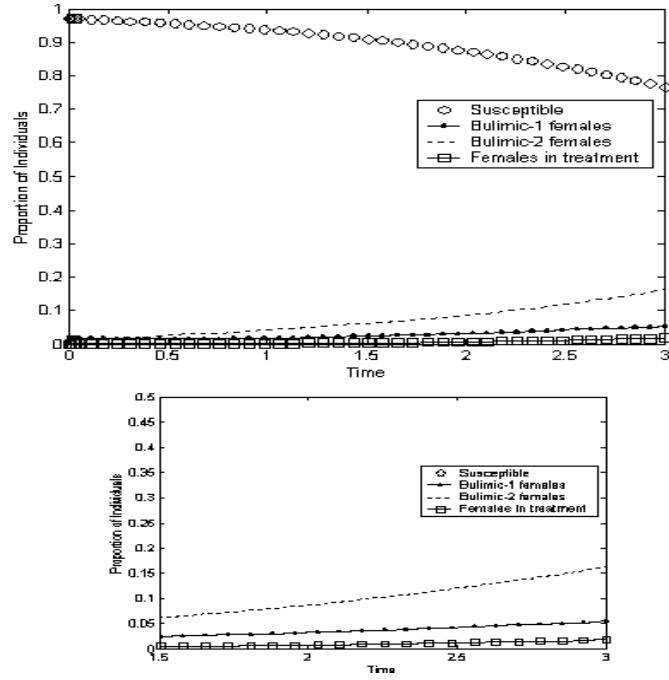

Figure 9: Parameter values:  $\mu=.33$ ,  $\phi=.01$ ,  $\rho=.083$ ,  $\delta=.3$ ,  $\gamma=2$ ,  $A=.8$ ,  $B_1=.02$ ,  $B_2=.01$  and  $R_0=1.475$ . In this graph above we increase the value of  $\gamma$  and we see that we have many  $B_2$

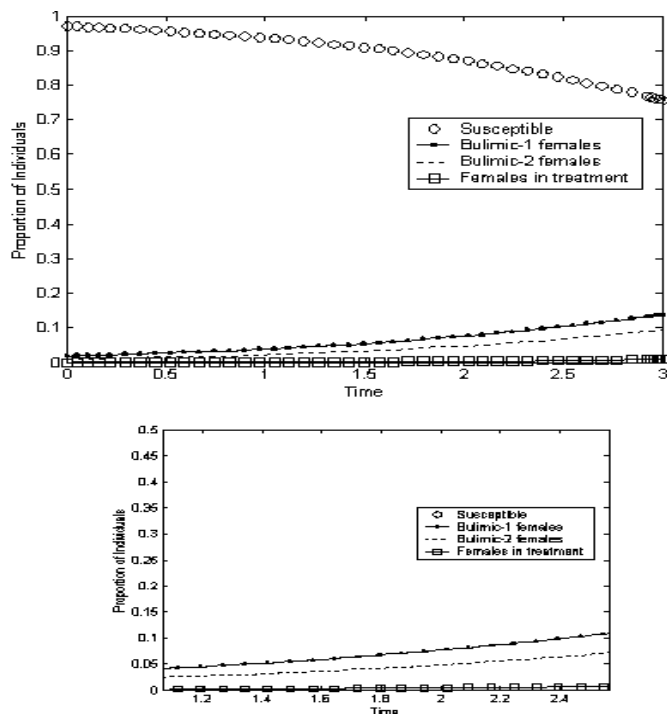

Figure 10: Parameter values:  $\mu=.33$ ,  $\phi=.01$ ,  $\rho=.083$ ,  $\delta=.3$ ,  $\gamma=.5$ ,  $A=.8$ ,  $B_1=.02$ ,  $B_2=.01$  and  $R_0=1.666$ . In this graph above we see that if we decrease the value of  $\gamma$  we have fewer  $B_2$  individuals. This is an illustration of what would happen if treatment was offered at  $B_1$

## 7 Conclusion

In our simulations, we changed the values for  $\gamma$  to see the effect it would have. If  $\gamma$  decreases then the number of  $B_2$  decreases. If  $\gamma$  increases, then the number of  $B_2$  increases. We found that the treatment that is currently offered at stage  $B_2$  is not very effective. It is not very effective in fighting the disease because it is not well-placed. Infected individuals need to get worse otherwise no treatment will be given. If treatment was offered at an earlier stage, then the number of individuals developing advance bulimia would decrease. We realize that it would be more effective to treat bulimics at an earlier stage ( $B_1$ ) rather than wait until the disease has become more critical. It would be more successful if treatment was given right after the person became infected with  $B_1$ . It is true that females infected with  $B_1$  rarely go to treatment,

but it would be a good idea to publicize this issue more. It is important to make these students realize that they have a problem that needs to be treated. It is very difficult to stop once the bingeing and the purging have begun. Thus, prevention should be a combination of treatment for  $B_1$ , education for susceptibles, and more counseling made available for students. The belief "be thin=pretty" should be abolished, because thinness does not create happiness. There should be a campaign that can explain explicitly why eating disorders are dangerous.

## 8 Future Work

It would be interesting to work with Model 1 and Model 2 where more than four factors are incorporated. Models consisting of more factors that would make it more realistic, but much more complicated.

Doing more research in the bifurcation graph section. To find out whether or not, a semi-backward bifurcation is possible.

Working with the parameters to find more realistic parameters, and getting interesting results.

## 9 Acknowledgements

We would like to thank the NSF for grant # DMS-9977919 and for grant # MDA 904-00-1-0006. Many thanks to the Sloan Foundation (Cornell-Sloan National Pipeline Program in the Mathematical Sciences), and last but not least, to the Office of the Provost at Cornell University. We would like to thank you for making research programs like MTBI possible. We really appreciate being here, and we know that it would not be possible without your support. Being at programs like this are very enriching, therefore we all cannot be but thankful.

We would like to thank everybody who makes MTBI possible. We would also like to thank MTBI for giving us the opportunity to do research. Special thanks to Carlos Castillo-Chavez for being so helpful, and always finding various ways of helping us. Thank you for all the advice that you gave us. Also many special thanks to Christopher Kribs-Zaleta for mentoring us in our project, for being there when we needed him. Thanks to Sophonie Nshinyabakobeje, Fabio Sanchez, and thanks to the staff, for making us feel comfortable. We have learned many new things that have opened new horizons. Thank you for the great opportunity.

## 10 References

### References

- [1] Anorexia Nervosa and Related Eating Disorders, Inc.(ANRED), <http://www.anred.com/stats.html>, copyright-2001
- [2] Benninnghoff, Jessica, <http://www.geocities.com/CapeCanaveral/Launchpad/8264/photo.htm>, accessed July 2001
- [3] Brauer, Fred. Next-Generation. Lecture in July, 2001
- [4] Castillo-Chavez C., Feng Z, and Huang W; *On the Computation of  $R_0$  and its role on global stability*, in Mathematical Approaches for emerging and re-emerging infectious diseases, Part I, IMA vol.125, New York: Springer-Verlag, pp. 224 – 250
- [5] Davis W, Whitaker L; *The Bulimic College Student*. Binghamton, NY, Haworth Press, 1989
- [6] Diekmann O, Heesterbeek JAP, and Metz JAJ: *On the definition and the computation of the basic reproduction ratio  $R_0$  in models for infectious diseases in heterogeneous population*, J. Math. Biol. 28:365 – 382
- [7] Drownowski A, Krahn DDD, Yess DK: *Bulimia in College Women: Incidence and Recovery Rates*. am J Psychiatry 145:753 – 755
- [8] Gordon, Richard A: *Anorexia and Bulimia, Anatomy of a Social Epidemic*. Basil Blackwell, Inc., Cambridge, Massachusetts, 1990
- [9] Halmi KA, Falk JR, Schwartz E: *Binge-eating and vomiting: a survey of a college population*. Psychol Med 11:697-706, 1981
- [10] Kaplan A, Olmsted M, and Rockert W: *Rate and prediction of Relapse in Bulimia Nervosa*. Am J Psychiatry 1994;151:738 – 743
- [11] Mirasol, the Arizona Centerfor Eating Disorders Recovery, <http://www.mirasol.net/enrollment.html>, accessed July 2001



- [12] Our Health, Our Futures, <http://www.smith.edu/ourhealthourfutures/anorexia.html>. Updated on August 3, 2001
- [13] Rowan, Peter, Dr. at Priory Hospital(in UK), <http://www.priory-hospital.co.uk/htm/bulimi.htm>, updated February 2001
- [14] Schlundt, David G. and Johnson, William G.:*Eating Disorders, Assessment and Treatment*. A Division of Simon and Schuster, Inc., Needham Heights, Massachusetts, 1990(pxi)
- [15] Steiner, Hans:*Anorexia nervosa and bulimia nervosa in children and adolescents: a review of the past 10 years*, April 1998. Website: <http://www.findarticles.com>
- [16] Support, Concern and Resources For Eating and Resources For Eating Disorders(S.C.a.R.E.D.), <http://www.eating-disorder.org/facts.html>, updated on March 27, 2001
- [17] Westwind, <http://www.westwind.mb.ca/westwind>, copyright 1999

## 11 Appendix

### 11.1 Simulations

The Matlab simulations used to generate the results of the section 6 were done using the program below. The parameters value are indicated in the graphs.

```
function y=plotbuli(tf,ph,r,d,g,a,s,B1,B2)
global phi rho delta gamma alpha sigma totB1 totB2
close phi=ph;rho=r;delta=d;gamma=g;alpha=a;sigma=s;totB1=B1;totB2=B2;
tspan=[0,tf]; [t,x]=ode45('buli',tspan,[1-(totB1+totB2);totB1;totB2;0]);
%plot(t,x(:,2)+x(:,3),'.-'); plot(t,x(:,1),'ko');
hold on
plot(t,x(:,2),'.-');
%hold on plot(t,x(:,3),'r:');
plot(t,x(:,4),'gs-');
xlabel('Time');
ylabel('Proportion of Individuals');
legend('Susceptible','Bulimic-1 females','Bulimic-2 females','Females in treatment')
```

```
function dx=buli(t,x)
%S in our system is x(1)
```

```
%B1 in our system is x(2)
%B2 in our system is x(3)
%T in our system is x(4)
global phi rho delta gamma alpha sigma
dx=[-(alpha-sigma)*x(1)*(x(2)+x(3));
(alpha-sigma)*x(1)*(x(2)+x(3))-gamma*x(2);
gamma*x(2)-delta*x(3)*x(4)-rho*x(3)+phi*x(4);
delta*x(3)*x(4)+rho*x(3)-phi*x(4);]
```