

# Raves, Clubs, and Ecstasy: The Impact of Peer Pressure

CORNELL UNIV., DEPT. OF BIOMETRICS TECHNICAL REPORT BU-1581-M

**Melissa Castillo-Garsow** (*Ithaca High School*)

**Leilani Henson** (*Howard University*)

**Marcin Mejran** (*Stuyvesant High School*)

**Karen R. Ríos-Soto** (*University of Puerto Rico-Mayaguez*)

**Advisor: Baojun Song** (*Cornell University*)

August 2001

## Abstract

MDMA (3,4 Methylendioxyamphetamine), commonly known as ecstasy, is a synthetic psychoactive drug, which in recent years has gained popularity among young adults who frequent raves and nightclubs (United States Department of Justice, 2001). In fact, the Drug Enforcement Administration reported a 500% increase in the use of ecstasy between 1993 and 1998 (National Clearinghouse for Alcohol and Drug Abuse, 2000). In this study, a system of four nonlinear differential equations is used to model the peer-driven dynamics of ecstasy use. It is found that two backwards bifurcations describe situations when sufficient peer pressure can cause an epidemic of ecstasy use despite conditions predicting the opposite trend. Furthermore, factors, which have the greatest influence on ecstasy use, as predicted by the model, are highlighted. The impact of education is also explored, and the results of simulations using parameter values, are shown to illustrate some of the possible outcomes.

# 1 Introduction

Between 1993 and 1998, the Drug Enforcement Administration documented a 500 percent increase in the use of ecstasy, an illicit drug best known for its popularity in the rave and night club culture [30]. Scientifically termed MDMA (3,4 Methylendioxyamphetamine), ecstasy is a synthetic drug with stimulant and hallucinogenic characteristics similar to methamphetamines. First patented in 1912 by a German pharmaceutical company as an appetite suppressant, ecstasy was used by a small number of therapists in the 1970s to enhance communication with patients [2]. Illicit use of the drug did not become popular in the United States until the late 1980s, and since then its abuse has increased dramatically [8].

Ecstasy, often called the “feel good” drug, produces feelings of empathy, sensuality, extreme relaxation, and elimination of anxiety. Used most commonly at raves, (large dance parties featuring loud techno music and lasting all night to a few days), ecstasy enables its users to go for long periods of time without food, drink, or sleep. It is most often taken in pill form, and its effects last four to six hours [9].

Ecstasy use, however, has an extremely ugly side, causing both immediate and long-term side effects. This drug increases the temperature of the body, blood pressure, and heart rate, often leading to severe dehydration and/or exhaustion. Other physical effects include muscle tension, involuntary teeth clenching, nausea, blurred vision, rapid eye movement, faintness, chills, and sweating. Additionally, although ecstasy is not physically addictive, it is thought to produce drug cravings through its psychological side effects, which can occur either during use or weeks after taking the drug. Confusion, depression, sleep problems, anxiety and paranoia are all other possible psychological difficulties resulting from ecstasy use [9]. Furthermore, recent research has linked ecstasy use to long-term brain damage in areas critical to thought and memory [22].

In recent years, ecstasy use has become increasingly popular with teens and young adults, especially those who live in urban areas where nightclubs and raves are common. Ecstasy is most rampant among Caucasians and Hispanics in the middle to upper middle classes, with prevalence estimates among African Americans remaining very low. In a 2000 study by the United States Office of National Drug Control Policy, 12th graders were found to be the greatest users of ecstasy with 8.2 percent reporting that they had used the drug in the past year. According to the study, 5.4 percent of tenth graders, 3.1 percent of 8th graders, 5.5 percent of college students and 3.6 percent of young adults (ages 18-28) reported using ecstasy in the past year [24].

Although ecstasy use is just beginning to become trendy and has not yet spread to many rural areas, its diffusion into the young population is especially alarming because of the speed with which it has gained popularity. The spread of ecstasy is also

cause for concern because of the perception among many young adults that ecstasy is as easily available and not as harmful as other drugs [23]. In addition, this increase in ecstasy use has come at a time when the rates in use of other drugs have either stabilized or begun to decrease [15].

This paper aims to show the influence of peer pressure on the prevalence of ecstasy use. By studying a core population of individuals between the ages of 13 and 25 who frequent raves and nightclubs, it is possible through the use of a system of nonlinear differential equations to provide that once drawn into the core population, preventing ecstasy use is very difficult. It is also shown that elimination of the susceptible core population, individuals who are not yet ecstasy users, is extremely difficult. This model will also provide, via analysis of threshold conditions and estimation of parameters, predictions for the future of ecstasy growth in the United States. Finally, by using simulations of different parameter values, we can recommend a method of combating ecstasy use with education.

## 2 A Population Model for the Use of Ecstasy

This model focuses on a population of individuals between the ages of 13 and 25, who are divided into four classes or subpopulations. The non-core subpopulation,  $A(t)$ , consists of individuals who never use ecstasy and do not frequent raves and nightclubs. The core population is composed of three classes  $S, I, V$  who regularly visit nightclubs and raves. The susceptible class,  $S(t)$ , are individuals who do not use ecstasy but are likely to become ecstasy users because of their immersion in the rave and nightclub culture. The ecstasy class,  $I(t)$ , are individuals who are habitual ecstasy users. The recovered class,  $V(t)$ , are individuals who are no longer using ecstasy. We treat the people that use ecstasy as an infected group in order to show the effect of peer pressure on the transmission of ecstasy use.

An individual can enter the population through class ( $A$ ), as a member of the non-core. Individuals in the non-core class ( $A$ ) can become susceptibles ( $S$ ) via  $S$  and  $I$  peer pressure, and return to  $A$  also by peer pressure. Once they are susceptible they can become ecstasy users due to peer pressure from  $I$ . An individual who becomes an ecstasy user, may quit by moving to the recovered class ( $V$ ). Former ecstasy users, can go back to the infected class ( $I$ ) or to the non-core class ( $A$ ).

Peer pressure results from interactions between core and non-core individuals, assumed to be proportional to the fraction of individuals who exert peer pressure. Furthermore, peer pressure could be positive (moving individuals out of the core) or negative (moving individuals into the core).

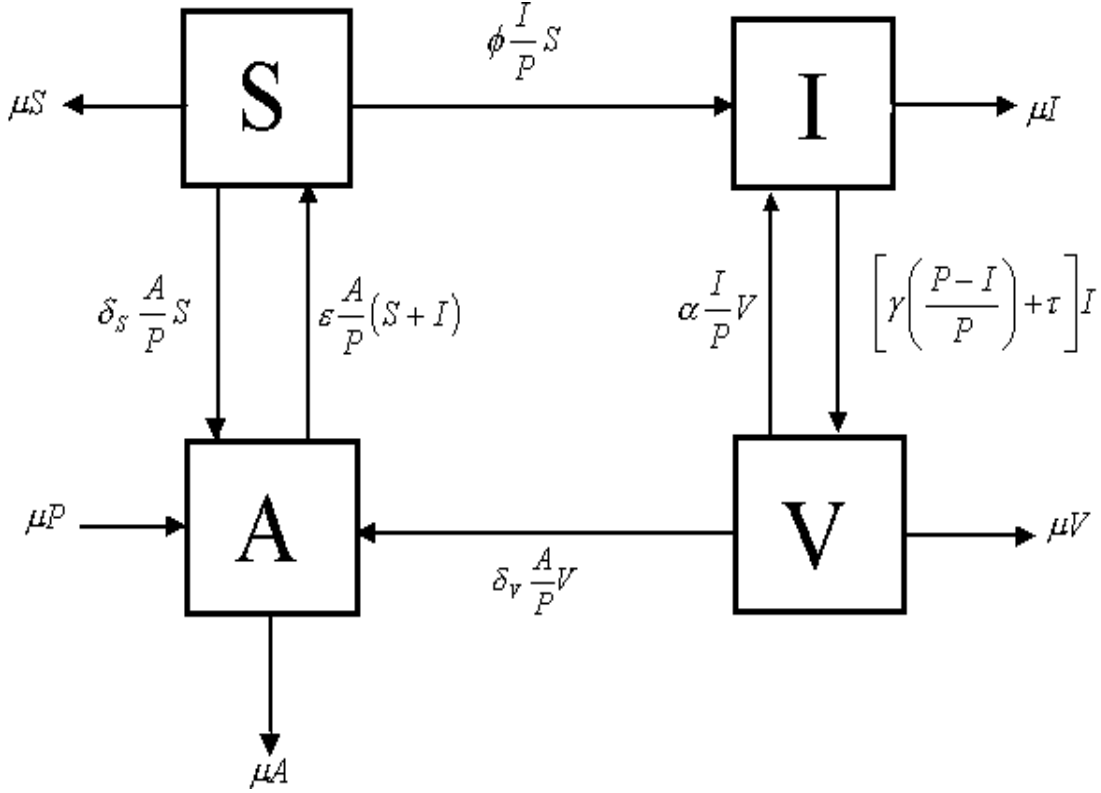

Figure 1: Ecstasy model

Our mathematical model is given by the following system of non-linear ordinary differential equations:

$$\frac{dA}{dt} = \mu P + \left( \delta_v \frac{V}{P} + \delta_s \frac{S}{P} - \epsilon \frac{(S+I)}{P} - \mu \right) A, \quad (1)$$

$$\frac{dS}{dt} = \epsilon \frac{A}{P} (S+I) - \left( \delta_s \frac{A}{P} + \phi \frac{I}{P} + \mu \right) S, \quad (2)$$

$$\frac{dI}{dt} = \left( \phi \frac{S}{P} + \frac{\alpha V}{P} - \left[ \gamma \left( \frac{P-I}{P} \right) + \tau \right] - \mu \right) I, \quad (3)$$

$$\frac{dV}{dt} = \left[ \gamma \left( \frac{P-I}{P} \right) + \tau \right] I - \left( \delta_v \frac{A}{P} + \frac{I}{P} \alpha + \mu \right) V, \quad (4)$$

where  $P = A + S + I + V$ .

We can check whether or not the total population ( $P$ ) is constant by adding the above

equations. This summation of the differential equations gives a result of 0, and so the model assumes that the population of 12 to 25 year olds does not fluctuate.

The parameters are defined in Table 1, shown below:

<i>Parameter</i>	<i>Definition</i>
$\mu$	Mortality rate and the rate of leaving a class as a result of aging.
$\epsilon$	Peer pressure rate of the core population on the non-core population.
$\phi$	Peer pressure rate of ecstasy users on susceptibles.
$\tau$	Recovery rate without peer pressure.
$\gamma$	Recovery rate from peer pressure.
$\alpha$	Relapse rate due to peer pressure.
$\delta_v$	Rate at which recovered individuals go back to the non-core as a result of peer pressure.
$\delta_s$	Rate at which susceptible individuals go back to the non-core due to peer pressure.

*Table 1. Parameters*

Note that all the parameters, excluding  $\mu$  and  $\tau$ , take into consideration the effect of peer pressure.

In order to simplify the system, we rescale it by introducing the non-dimensional variables  $x = \frac{A}{P}$ ,  $y = \frac{S}{P}$ ,  $z = \frac{I}{P}$ ,  $w = \frac{V}{P}$ . The new system is

$$\frac{dx}{dt} = \mu + (\delta_s y - \epsilon(y + z) + \delta_v w - \mu)x, \quad (5)$$

$$\frac{dy}{dt} = \epsilon x(y + z) - (\phi z + \delta_s x + \mu)y, \quad (6)$$

$$\frac{dz}{dt} = (\phi y + \alpha w - [\gamma(1 - z) + \tau + \mu])z, \quad (7)$$

$$\frac{dw}{dt} = [\gamma(1 - z) + \tau]z - (\delta_v x + \alpha z + \mu)w, \quad (8)$$

$$x + y + z + w = 1.$$

The analysis of the model uses this rescaled version. Since P (our total population is constant, results will also hold for the original model.

### 3 Analysis

#### 3.1 Core-Free and Ecstasy-Free Equilibria and the Basic Reproductive Numbers

From analysis of the rescaled model, we found that  $(x, y, z, w) = (1, 0, 0, 0)$  is an equilibrium, which we call the core-free equilibrium.

The Jacobian matrix at the core-free equilibrium is

$$\begin{pmatrix} -\mu & \delta_s - \epsilon & -\epsilon & \delta_v \\ 0 & \epsilon - \delta_s - \mu & \epsilon & 0 \\ 0 & 0 & -\gamma - \tau - \mu & 0 \\ 0 & 0 & \gamma + \tau & -\delta_v - \mu \end{pmatrix}.$$

This matrix has four eigenvalues, three negatives

$$-\mu, -(\gamma + \tau + \mu), -(\delta_v + \mu),$$

and

$$\epsilon - \delta_s - \mu.$$

Hence, local asymptotical stability is guaranteed provide that  $\epsilon < \delta_s + \mu$ . Therefore if we define:

$$R_c = \frac{\epsilon - \delta_s}{\mu}, \tag{9}$$

We can conclude that whenever  $R_c < 1$ , the core-free equilibrium is locally asymptotically stable, while unstable if  $R_c > 1$ . We will show that if  $R_c < 1$ , then the core-free equilibrium is globally asymptotically stable provided that  $\epsilon < \mu$ . When this condition is not met, the core-free equilibrium is only locally asymptotically stable and a backward bifurcation may occur. This will be shown numerically.

$R_c$  can be easily interpreted as the product of the net peer pressure felt by the non-core class to begin going to raves and night clubs ( $\epsilon - \delta_s$ ) times the average life-span in the system  $\left(\frac{1}{\mu}\right)$ . Note that departure from the susceptible core is due to aging, mortality or peer pressure from the non-core population. In other words,  $R_c$  denotes the number of converts into the core group per-core member when the core group population is very small.  $R_c > 1$ , naturally leads to the establishment of a critical mass of susceptibles. Typically  $R_c < 1$  would imply that a core cannot be established. However, if peer pressure is large enough, this is not the case.

The equilibrium conditions also give the following ecstasy-free equilibrium

$$(x, y, z, w) = \left( \frac{\mu}{\epsilon - \delta_s}, 1 - \frac{\mu}{\epsilon - \delta_s}, 0, 0 \right).$$

Note that the ecstasy-free equilibrium can also be written as

$$(x, y, z, w) = \left( \frac{1}{R_c}, 1 - \frac{1}{R_c}, 0, 0 \right).$$

The Jacobian matrix at the ecstasy-free equilibrium is:

$$\begin{pmatrix} \delta_s - \epsilon & -\mu & \frac{-\epsilon\mu}{\epsilon - \delta_s} & \frac{\delta_v\mu}{\epsilon - \delta_s} \\ \epsilon - \delta_s - \mu & 0 & \frac{\epsilon\mu - \phi(\epsilon - \delta_s - \mu)}{\epsilon - \delta_s} & 0 \\ 0 & 0 & \frac{\phi(\epsilon - \delta_s - \mu)}{\epsilon - \delta_s} - \gamma - \tau - \mu & 0 \\ 0 & 0 & \gamma + \tau & -\mu\left(\frac{\delta_v}{\epsilon - \delta_s} + 1\right) \end{pmatrix}.$$

This equilibrium only exists when  $\frac{\mu}{\epsilon - \delta_s} < 1$  (when  $R_c > 1$ ); therefore when the core-free equilibrium becomes unstable the ecstasy-free equilibrium is born.

Since this equilibrium only exists when  $\epsilon > (\delta_s + \mu)$ , the matrix has four eigenvalues, three negative,

$$-\mu\left(\frac{\delta_v}{\epsilon - \delta_s} + 1\right), (\delta_s + \mu) - \epsilon, -\mu,$$

and

$$\frac{\phi(\epsilon - \delta_s - \mu)}{\epsilon - \delta_s} - \gamma - \tau - \mu;$$

when this is negative, we have

$$\frac{\phi(\epsilon - \delta_s - \mu)}{\epsilon - \delta_s} < \gamma + \tau + \mu.$$

We define the basic reproductive number as:

$$R_0 = \frac{\phi\left(1 - \frac{\mu}{\epsilon - \delta_s}\right)}{\gamma + \tau + \mu}, \quad (10)$$

If  $R_0 < 1$ , the ecstasy-free equilibrium point is locally asymptotically stable.  $R_0 < 1$  then would typically imply an ecstasy-free population. This, however, is not entirely correct. Later we will find that values of  $R_0 < 1$  may also imply the existence of multiple endemic equilibrium and a backward bifurcation.

The basic reproductive number,  $R_0$ , is given by the product of peer pressure, the maximum proportion of susceptibles in the population, and the average ecstasy conversion period. Notice that  $\frac{1}{\gamma+\tau+\mu}$  is the average time that an individual uses ecstasy. While  $1-\frac{\mu}{\epsilon-\delta_s}$  is the maximum proportion of the population that is susceptible and  $\phi$  is the peer driven infection rate. Therefore,  $R_0$  describes the conditions ecstasy must overcome to infect more individuals.

In summary,  $R_c$  and  $R_0$  are local “tipping” points, that is, thresholds based on local conditions. Peer pressure destroys the hope of global tipping points and enhance the persistence of ecstasy use and an ecstasy favorable environment.

Looking at  $R_0$  and  $R_c$ , we can analyze the sensitivity of the system by observing the parameters that can dramatically change either one or both of the values of the basic reproductive numbers. Despite the limitations, we will still look at the impact of parameters on the values of  $R_c$  and  $R_0$  in order to evaluate the impact of education on this system. The value of  $\phi$ , which is the infection rate, has an important effect on  $R_0$ , and the value of  $\epsilon$ , the recruitment rate from the non-core class into the susceptible class, has an important effect on both  $R_0$  and  $R_c$ .

### 3.2 Global Stability of the Core-free Equilibrium

The global stability of the core-free equilibrium is established using the Lyapunov method. The following theorem is taken from *Nonlinear Dynamics and Chaos* by Steven Strogatz [26].

*For  $\dot{x} = f(x)$ ,  $x^*$  is a critical point ( $f(x) = 0$ )  $f \in C^1$ . Suppose that there exists a function  $V(x) \in C^1$  satisfying:*

1.  $V(x) > 0$  for all  $x \neq x^*$ ,  $V(x^*) = 0$
2.  $\frac{dV}{dt} = DV_x \leq 0$  for all  $x \neq x^*$

Then  $x^*$  is globally asymptotically stable (G.A.S.).

We intend to prove the following: *If  $\epsilon < \mu$ , and  $R_c < 1$ , the core-free equilibrium  $(1, 0, 0, 0)$  is globally asymptotically stable (G.A.S).*

Proof:

We select the Lyapunov function  $L(S, I, V) = S + I + V$ .  
 $L(S, I, V) \geq 0$  since S, I, V are nonnegative. Check  $\frac{dL}{dt}$ :



$$\begin{aligned}
\frac{dL}{dt} &= \frac{dS}{dt} + \frac{dI}{dt} + \frac{dV}{dt} \\
&= \epsilon A \frac{(S+I)}{P} - \left( \delta_s \frac{A}{P} + \mu \right) S - \mu I - \mu V - \delta_v V \\
&= \epsilon S \frac{A}{P} + \epsilon I \frac{A}{P} - \left( \delta_s \frac{A}{P} + \mu \right) S - \mu(I+V) - \delta_v V \frac{A}{P} \\
&\leq \epsilon I - \mu I + \left( \delta_s \frac{A}{P} + \mu \right) S \left( \frac{\epsilon \frac{A}{P}}{\delta_s \frac{A}{P} + \mu} - 1 \right) \\
&\leq \left( \delta_s \frac{A}{P} + \mu \right) S \left( \frac{\epsilon \frac{A}{P}}{\delta_s \frac{A}{P} + \mu} - 1 \right) \\
&\leq \left( \delta_s \frac{A}{P} + \mu \right) S \left( \frac{\epsilon}{\delta_s + \mu} - 1 \right) \quad \text{since } \left( \frac{\epsilon x}{\delta_s x + \mu} \right) \text{ is an increasing function of } x \\
&< \left( \delta_s \frac{A}{P} + \mu \right) S (R_c - 1) \\
&< 0 \quad (\text{since } R_c < 1).
\end{aligned} \tag{11}$$

Thus the core-free equilibrium is globally asymptotically stable, whenever  $R_c < 1$  and  $\epsilon < \mu$ . Since  $\mu$  is so small, this is a very restrictive assumption. When estimating parameters, we have found, in research, that  $\epsilon$  should be larger than  $\mu$ . Therefore, we recognize that  $\epsilon < \mu$  implies that when  $R_c < 1$ , the population will become entirely non-core, despite any initial conditions, and only look numerically at  $\epsilon > \mu$ .

### 3.3 Endemic Equilibria

The previous subsection showed that if  $R_c < 1$  and  $\epsilon < \mu$ , then the core-free equilibrium is globally asymptotically stable, meaning that a sufficiently large core population does not exist. However, when  $R_c > 1$  and  $R_0 < 1$ , an ecstasy-free equilibrium, which is locally asymptotically stable, is born. We show numerically that in both of these cases a backward bifurcation and multiple equilibria are possible under certain conditions. Furthermore, we attend to solve the following nonlinear system of equation in order to explore whether or not there are positive endemic equilibria and to highlight the difficulties of this process.

$$\begin{aligned}
0 &= \mu + (\delta_s y - \epsilon(y+z) + \delta_v w - \mu)x, \\
0 &= \epsilon x(y+z) - (\phi z + \delta_s x + \mu)y, \\
0 &= \phi y + \alpha w - [\gamma(1-z) + \tau + \mu], \\
0 &= [\gamma(1-z) + \tau]z - (\delta_v x + \alpha z + \mu)w, \\
1 &= x + y + z + w.
\end{aligned}$$

Since the total population in our model is constant, we can simplify the system into four equations.

$$0 = \mu + (\delta_s y - \epsilon(y + z) + \delta_v w - \mu)x, \quad (12)$$

$$0 = \epsilon x(y + z) - (\phi z + \delta_s x + \mu)y, \quad (13)$$

$$0 = \phi y + \alpha w - [\gamma(1 - z) + \tau + \mu], \quad (14)$$

$$x + y + z + w = 1. \quad (15)$$

From (14)

$$\phi y + \alpha w + \gamma z = \gamma + \tau + \mu.$$

Adding (12 + 13) gives

$$0 = (z + w)\mu + \delta_v w x - \phi z y.$$

Therefore our new system is:

$$x = 1 - y - z - w, \quad (16)$$

$$0 = \phi y + \alpha w + \gamma z - (\gamma + \tau + \mu), \quad (17)$$

$$0 = (z + w)\mu + \delta_v w x - \phi z y, \quad (18)$$

$$0 = \epsilon x(y + z) - (\phi z + \delta_s x + \mu)y. \quad (19)$$

Replacing  $x$  with  $1 - w - z - y$  in (18) - (19)

$$0 = (z + w)\mu + \delta_v w(1 - w - z - y) - \phi z y \quad (20)$$

$$0 = \epsilon(1 - y - z - w)(y + z) - y(\phi z + \delta_s(1 - y - z - w) + \mu) \quad (21)$$

Solving for  $y$  in (16), we have

$$y = \frac{\gamma + \tau + \mu - \gamma z - \alpha w}{\phi} = f_y(z, w). \quad (22)$$

Replacing  $y$  in (19) and in (20), our new system for  $z$  and  $w$  is:

$$0 = (z + w)\mu + \delta_v w(1 - f_y(z, w) - z - w) - z(\gamma + \tau + \mu - (\gamma z + \alpha w)) \quad (23)$$

$$0 = [\epsilon(\phi f_z(w) + \mu) - f_y(z, w)\delta_s](1 - f_y(w) - f_z(w) - w) - f_y(z, w)(\phi z + \mu) \quad (24)$$

We rewrite (22) by

$$Az^2 + Bz + C = 0 \quad (25)$$

where,

$$\begin{aligned} A &= \gamma, & B &= (\gamma + \tau - \alpha w) - \delta_v w \left( \frac{\gamma}{\phi} - 1 \right), \\ C &= \mu w - \delta_v w \left( 1 - \frac{\gamma + \tau + \mu - \alpha w}{\phi} - w \right). \end{aligned}$$

Solving for  $z$  in (24) using the quadratic formula, we find that one of the solutions is

$$z = \frac{-B - \sqrt{B^2 - 4AC}}{2A} = f_z(w). \quad (26)$$

Replacing  $z$  with  $f_z(w)$  in (21), we obtain

$$f_y(w) = \frac{\gamma + \tau + \mu - \gamma f_z(w) - \alpha w}{\phi}. \quad (27)$$

Substituting  $z$  with  $f_z(w)$  and  $f_y(z, w)$  with  $f_y(w)$  into (23) yields an equation for  $w$ ,

$$F(w) = f_y(w)(\phi f_z(w) + \mu) + (1 - f_y(w) - f_z(w) - w)[f_y(w)(\delta_s - \epsilon f_z(w))] = 0 \quad (28)$$

$$F(0) = \left( \frac{\gamma + \tau + \mu}{\phi} \right) (\delta_s - \epsilon)(1 - R_c^{-1})(1 - R_0^{-1}) \quad (29)$$

The existence of at least one positive equilibrium should follow from the intermediate value theorem. It is clear that  $R_0 < 1$  implies that  $F(0) < 0$ . This demonstrates that there exists a  $w \in (0, 1)$ , such that  $F(w) > 0$  would guarantee the existence of at least a positive equilibrium. Similarly,  $R_0 > 1$  implies that  $F(0) > 0$  and finding a  $w \in (0, 1)$  such that  $F(w) < 0$  would conclude this proof. We have not been able to carry out this analysis but have shown this to be the case numerically for different values of parameters. Our results will be shown later in more general context.

For example, one case might be that the parameter values are the following:

$$\begin{aligned} \phi &= 0.1, & \mu &= 0.0174, & \epsilon &= 0.25, & \delta_s &= 0.22189, \\ \delta_v &= 0.0075, & \gamma &= 0.0065, & \tau &= 0.0045, & \alpha &= 0.8. \end{aligned}$$

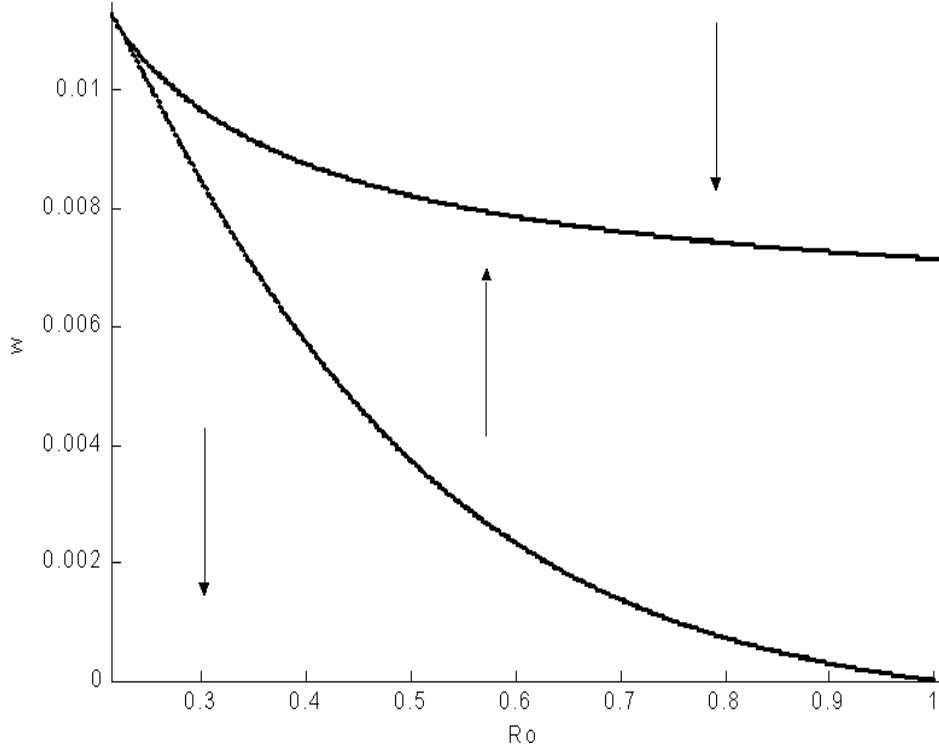

Figure 2: Bifurcation Diagram for the Endemic Equilibrium with the Recovered Class ( $w$ ).

From these values, we can write an equation for  $F(w)$  which, although very large, can be easily solved for all values of  $w$ . For instance:  $F(0) = -0.00003859$  and  $F(1) = 0.4071$ . Therefore, using the intermediate value theorem, we can prove the existence of at least one positive endemic equilibrium for these parameter values.

Actually solving for the equilibria, give us four positive solutions in the form  $(x, y, z, w)$ ; the core-free equilibrium  $(1, 0, 0, 0)$ , a ecstasy-free equilibrium  $(0.7978, 0.2022, 0, 0)$  and two endemic equilibria  $E_1 = (0.7222, 0.2735, 0.002942, 0.001283)$  and  $E_2 = (0.0853, 0.1759, 0.7313, 0.0076)$ .

In this case  $R_c = 1.001796$  and  $R_0 = 0.7120$ . By linearizing the equations with the substituted parameter values and analyzing eigenvalues, we find that there are two stable equilibria; the ecstasy-free equilibrium and  $E_2$ .

This is an example of a backwards bifurcation and is graphed in Figure 2 and 3. In summary, even though we cannot analytically prove the existence of endemic equilibria, we can show numerically that multiple equilibria exist.

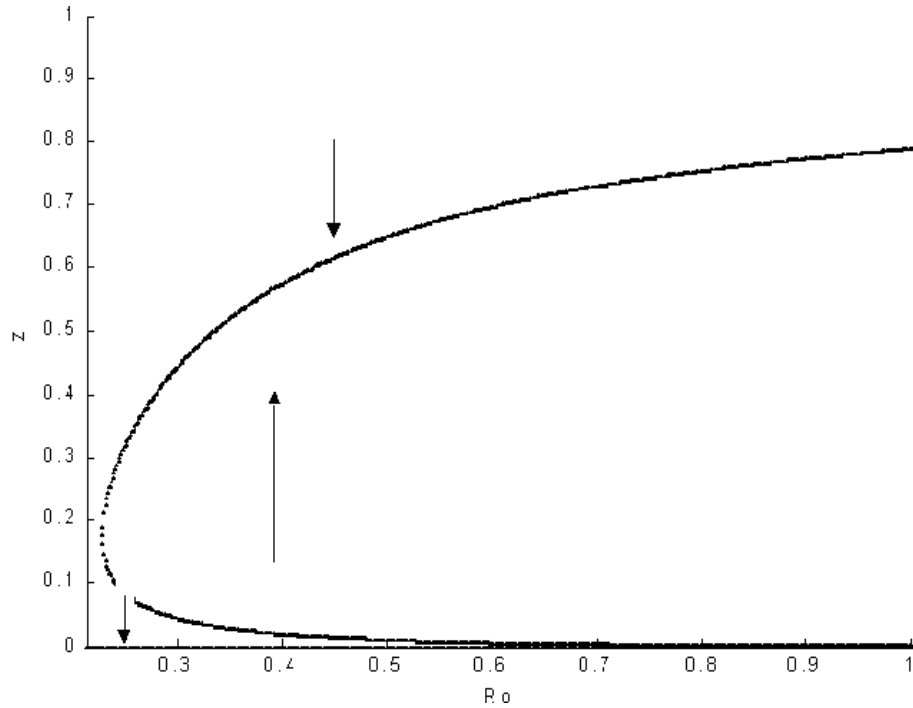

Figure 3: Bifurcation for the Endemic Equilibrium with the Infected Class ( $z$ ).

## 4 Estimation of Parameters

In order to study the model, it is necessary to estimate some of the values of the parameters so as to analyze the effect of peer pressure on ecstasy use and the possible outcomes, which occur with the addition of education into the system. However, because of the novelty of this topic, most research and statistics regarding ecstasy have only been done in the past five years. For example, “Monitoring the Future,” a survey of drug use administered by the United States Department of Health and Human Services, only began including ecstasy in its survey in 1996 [15]. Additionally, little research has been done specific to ecstasy regarding prevention, treatment, and its use as a gateway drug. Thus, all estimations of the parameters are rough approximations, some based on statistical data and others based on papers and books made up mostly of anecdotal information and generalizations. Note that the model deals with a specific age group (13-25 years old) and that the time scale is in months.

<i>Parameter</i>	<i>Value</i>
$\mu$	0.007
$\epsilon$	0.0391
$\phi$	0.275
$\tau$	0.016
$\gamma$	0.011
$\alpha$	0.5
$\delta_v$	0.05
$\delta_s$	0.032

*Table 2. Parameter Values*

$\mu - 0.007$ . The United States Census Bureau estimates that the number of individuals in the age group of the model is 50 million [29]. The number of non-ecstasy related deaths is around 35,000 per year [1]. 35,000 divided by 12 gives the average number of natural deaths per month, and that quotient over 50 million is the rate of death per individual. We add this figure to 1/144 months, because our system only looks at 12 years.

$\phi - 0.275$ . Using the US Departments of Health and Human Service’s Monitoring the Future Study, we estimated that the initial percentage of habitual ecstasy users is 7 percent and that the number of new infected individuals is approximately 2.1 percent per year [15]. Therefore, each ecstasy user infects approximately 3.3 individuals from the susceptible class each year. This number divided by 12 gives us  $\phi$ . Although this infection rate may seem very high, it is important to recognize that the infection is spread from a susceptible class made up of individuals who are frequent visitors of nightclubs and raves where ecstasy is widely used and easily available [2].

$\epsilon - 0.0391$ . In this case there is no data on the numbers or rates of people who frequently go to raves and/or nightclubs. We assume that the number of new susceptibles, those individuals who begin to frequent nightclubs and raves, is larger than the number of individuals who tried ecstasy in the past month. By estimating the percent change of ravers or nightclubbers as 0.375, we are able to approximate that a susceptible recruits .47 individuals per year. This number over 12 yields the value for  $\epsilon$ . This value ( $\epsilon$ ) is much smaller than  $\phi$  because of the different pools from which each is recruiting. Although more people go to nightclubs and raves than become habitual ecstasy users,  $\epsilon$  is recruiting from a very large non-core population that doesn’t use ecstasy and doesn’t go to these events. On the other hand, research has shown that at events like raves, a very large proportion of the population will use ecstasy [2].

$\delta_s - 0.032$ . In order for the ecstasy-free equilibrium to exist,  $\epsilon > (\delta_s + \mu)$  and consequently,  $\delta_s < 0.0321$ . We assumed that there is a fair amount of movement between the susceptible and non-core classes in selecting  $\delta_s$ . Again, here we are unable to find any research material on this parameter.

$\alpha = 0.5$ . Research has shown that once an individual has used and then stopped using a drug, it is much easier to relapse back into drug abuse than begin to abuse a drug for the first time [17]. Therefore,  $\alpha$  must be larger than  $\phi$ . We approximated that abuse of ecstasy a second time was at least twice as likely as abuse by a first timer and then rounded  $\alpha$  down a little to a conservative estimate of 0.5.

$\tau = 0.016$  and  $\gamma = 0.011$ .  $\tau$  is the recovery rate without peer pressure and includes both the rate of stopping ecstasy use in favor of a drug-free core life, but also the rate of moving onto abuse of substances other than ecstasy.  $\gamma$  incorporates the effect of peer pressure on both stopping drug use and moving onto other drugs. We conjecture that peer pressure does not have as much of an effect on removal from drug use or gateway drug usage as do other factors. Therefore,  $\tau$  must be bigger than  $\gamma$ . In any case, whether or not  $\tau$  is greater than  $\gamma$  does not make a difference in the results because of their position in  $R_0$ . An increase of a certain increment of  $\tau$  has the same effect as an increase of the equal amount in  $\gamma$ . Although we believe that  $\tau$  should be greater than  $\gamma$ , in terms of numerical results, only their sum is important.

Although there is no data available on recovery from ecstasy use or whether ecstasy is a gateway drug, we used estimates from methamphetamine, a drug used in similar settings with similar effects, but more widely researched, to estimate these recovery parameters. According to the “Monitoring the Future” study, approximately one third of methamphetamine users in 1998, did not use methamphetamine in 1999 [15]. This non-continuation rate, divided by 12 gave the value for the sum of  $\tau$  and  $\gamma$ . The final values for the two parameters were adjusted from simulations, as no data was available regarding these parameters for any illicit drug whatsoever.

$\delta_v = 0.05$ . This parameter is approximated out of comparison with  $\delta_s$ . Since the recovered class (V) is still in the core population, it represents a group of individuals who have stopped using ecstasy, yet still frequent raves and nightclubs. This population is fairly small. We assume that most people who refrain from using ecstasy do so by leaving the ecstasy culture, which embraces long dance parties. Therefore, a large portion of  $V$  will leave each year to go to the non-core population. Drug use can still continue in the non-core, so long as the drug of choice is not ecstasy and the setting is not a rave or nightclub.  $\delta_v$  is larger than  $\delta_s$  because once in the susceptible population an individual is much more likely to become infected than decide that s/he dislikes raves and nightclubs. Individuals leave the surroundings of raves and nightclubs at a higher rate from the recovered class than from the susceptible class because the recoveries have had the time and experience to see the dangers of ecstasy use and decide whether or not they enjoy the club scene.

## 5 Numerical Analysis

We simulated the model to look at the four cases; ( $R_c < R_0 < 1$ ), ( $1 < R_c < R_0$ ), ( $R_c < 1$  and  $R_0 > 1$ ) and finally ( $R_c > 1$  and  $R_0 < 1$ ). We did this by varying one or two parameters out of the set of estimated values. Note that in these simulations,  $\epsilon > \mu$  and so the core-free equilibrium is not globally asymptotically stable.

Results show that when  $R_c < R_0 < 1$ , the non-core population increases and approaches 1 while the core population of susceptibles, infected, and recovered decrease to zero. Given enough time, the non-core population will come to make up 100 percent of the population. See Figure 4.

For this case we used the following parameter values:

$$\begin{aligned} \phi &= 0.007, & \mu &= 0.007, & \epsilon &= 0.03, & \delta_s &= 0.032, \\ \delta_v &= 0.05, & \gamma &= 0.011, & \tau &= 0.016, & \alpha &= 0.5. \end{aligned}$$

Hence,  $R_c = 0.76923$  and  $R_0 = 0.92647$ .

When  $1 < R_c < R_0$ , the non-core population declines because the ecstasy class is growing.

For this case we used the same parameter values as the example above, except  $\phi = 2.75$ . Here,  $R_c = 1.0026$  and  $R_0 = 1.1392$ .

There is one stable endemic equilibrium in this situation, which for these parameters equals  $(0.1999, 0.0028, 0.7616, 0.0357)$ . These values describe the stabilized conditions that each class will approach over time. This predicts that the non-core class will become roughly 20 percent of the population, the susceptibles will make up 0.3 percent, the infected, 76.2 percent, and the recovered, 3.5 percent. See Figure 5.

If  $R_c < 1$  and  $R_0 > 1$ , a backward bifurcation describes the circumstance of locally stable endemic and core-free equilibriums.

Parameter values within this situation could be the following:

$$\begin{aligned} \phi &= 0.007, & \mu &= 0.275, & \epsilon &= 0.03, & \delta_s &= 0.032, \\ \delta_v &= 0.05, & \gamma &= 0.011, & \tau &= 0.016, & \alpha &= 0.5. \end{aligned}$$

In this simulation, we only change  $\phi$  to 0.275 from the last case, and we get  $R_c = 0.76923$  and  $R_0 = 36.3971$ . See Figures 8 and 9.



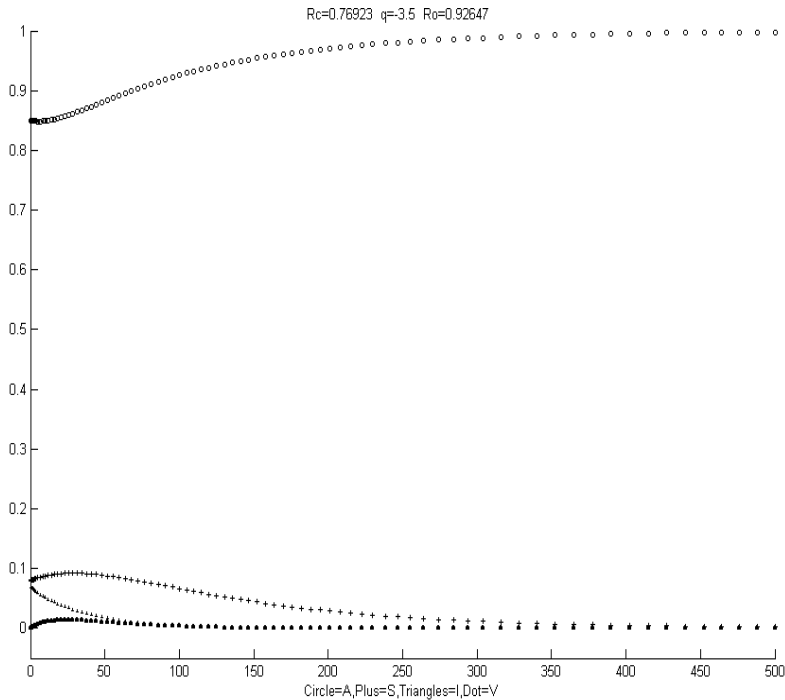

Figure 4:  $R_c < R_0 < 1$

In a simple model with just one basic reproductive number,  $R_0$ , a backward bifurcation describes a condition of multiple endemic equilibrium existing when  $R_0 < 1$ . In other words, a disease can persist when  $R_0 < 1$  and a sufficient number of infectives are introduced into the population. As  $R_0$  passes 1, the disease establishes a large endemic state, which can only be eradicated by reducing  $R_0$  to the point where the bifurcation ends. This value of  $R_0$  corresponds to the state when the endemic equilibrium disappears [16].

In this situation, both the core-free equilibrium and the endemic equilibrium are locally asymptotically stable, while a positive ecstasy-free equilibrium does not exist. For the above mentioned parameters, the two endemic equilibria are  $E_1 = (0.7906, 0.0676, 0.1134, 0.0283)$  and  $E_2 = (0.2860, 0.0299, 0.6468, 0.0373)$ . By analyzing the eigenvalues, we know that  $E_2$ , the endemic equilibrium with the higher  $z$  value is locally asymptotically stable.

This bifurcation occurs between two separate boundaries. First, when  $\epsilon < \mu$ , the core-free equilibrium becomes globally asymptotically stable. For example, when  $\epsilon = 0.006999$ ,  $R_c = 0.1795$  and  $R_0 = 10.3439$  and this bifurcation no longer happens. On the other spectrum, when  $\epsilon = 0.039$ ,  $R_c = 1$  and  $R_0 = 0$ . If  $\epsilon$  is any larger,  $R_c$  becomes greater than 1 and  $R_0 < 1$ , which is a condition described by a differ-

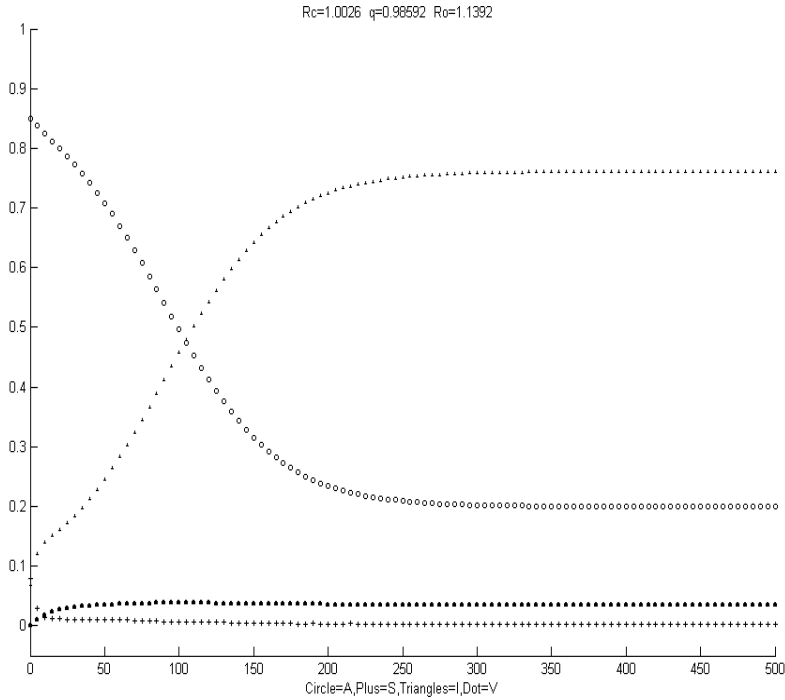

Figure 5:  $1 < R_c < R_0$

ent bifurcation (discussed in the next case). Therefore this bifurcation occurs when  $0.1795 < R_c < 1$  and  $R_0 > 10.3439$  for these parameter values.

In a backward bifurcation, solutions go to a certain equilibrium depending on the basins of attraction of each equilibrium. In this case, the equilibrium where the susceptibles made up approximately 3 percent of the population, the infected made up 64.7 percent of the population; the non-core, 28.6 percent; and the recovered, 3.7 percent; was stable. Hence, if the number of susceptibles is in the basin of attraction for the stable endemic equilibrium, a large increase in the infected class can still occur. This backward bifurcation means that even if the rates for leaving the susceptible class are higher than the rates of moving into the susceptible class, the susceptible class can still sustain an epidemic of ecstasy use. If enough people are frequently going to raves and nightclubs to begin with, the population using ecstasy can grow despite a declining susceptible class.

Our estimate of an initial population of susceptible of 8 percent was enough to create an epidemic of going to raves and nightclubs. Since the population in the susceptible class is not big enough to create this epidemic, the class decreases to zero as described in the core-free equilibrium. Therefore, the susceptible can not provide a base population for the infected class and the number of ecstasy users decline. As

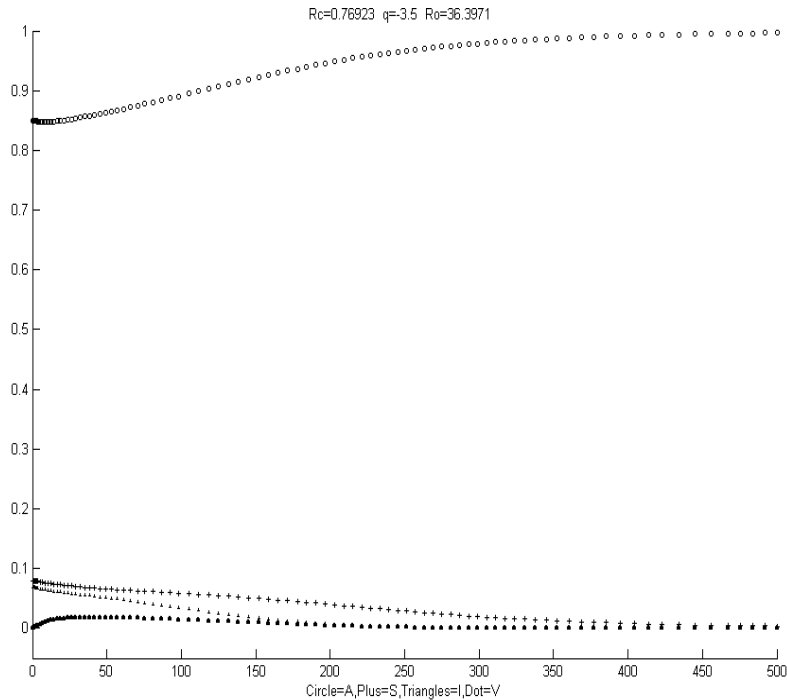

Figure 6:  $R_c < 1$  and  $R_0 > 1$

described in the core-free equilibrium, the susceptible, infected, and recovered class stabilized at zero, while the non-core class becomes the whole population, Figure 6.

If  $R_c > 1$  and  $R_0 < 1$  two situations can happen because of the backward bifurcation occurring in this system.

In this illustration, we used the following parameters:

$$\begin{aligned} \phi &= 0.275, & \mu &= 0.007, & \epsilon &= 0.0391, & \delta_s &= 0.032, \\ \delta_v &= 0.05, & \gamma &= 0.011, & \tau &= 0.016, & \alpha &= 0.5. \end{aligned}$$

Note that only  $\epsilon$  was changed from the last case. Here,  $R_c = 1.0026$  and  $R_0 = 0.11392$ .

Let  $R_e$  denote the value of  $R_0 < 1$  when the backward bifurcation no longer occurs and the endemic states cease to exist. By fixing all the parameters except for  $\phi$  and then varying this last parameter, we can find the condition of  $R_0$  when the backward bifurcation ends to be  $R_e = 0.015$ . When  $0.015 < R_0 < 1$ , the model exhibits this bifurcation and if  $R_0 < 0.015$ , the classes will stabilize at the ecstasy-free equilibrium.

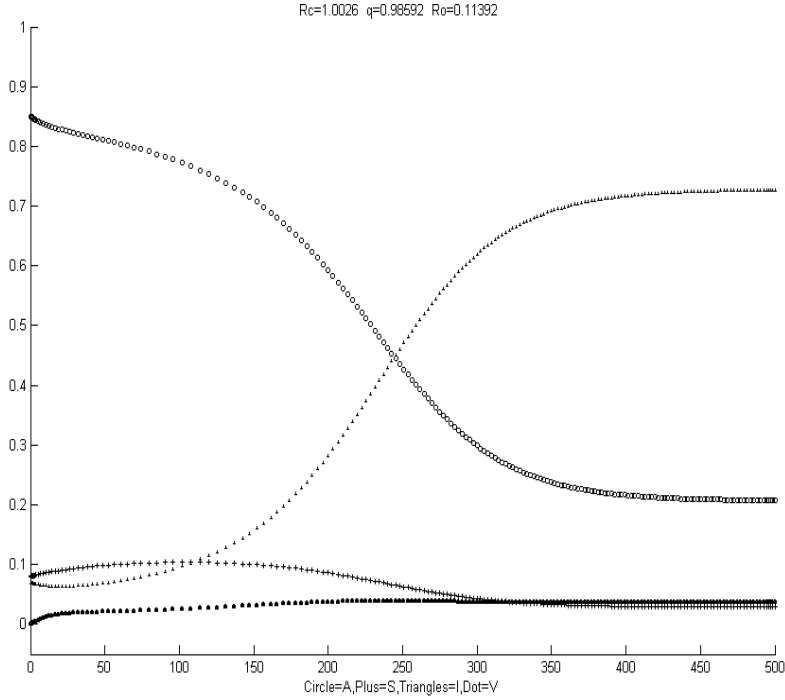

Figure 7:  $R_e > 1$  and  $R_0 < 1$

In the latter case, the infected and recovered classes will decrease to zero, and the susceptible and non-core classes will stabilize to a certain proportion of the total population based on the parameter values  $\mu$ ,  $\epsilon$  and  $\delta_s$ , which are in this equilibrium. For these parameters, since the ecstasy-free equilibrium is  $(0.9858, 0.0142, 0, 0)$ , the non-core population will become approximately 98.6 percent of the population and the susceptibles will decline to 1.4 percent of the population.

On the other hand, if  $R_e < R_0 < 1$ , the model is described by a backward bifurcation. Here, there are two endemic equilibria, one stable and one unstable. The equilibrium,  $E_2 = (0.2066, 0.0286, 0.7285, 0.0362)$  with the larger infection or  $z$  value is locally asymptotically stable, while the other  $E_1 = (0.8642, 0.1064, 0.0203, 0.0090)$  is unstable. The ecstasy-free equilibrium is also locally asymptotically stable. Therefore, for these parameters, if ecstasy is at an epidemic level,  $R_0$  must be reduced below 0.015 in order to get rid of ecstasy use. The results from these parameters then suggest that ecstasy use is extremely difficult to get rid of. See Figures 10 and 11.

Figures 10 and 11 show two variations of the bifurcation for this system. The first plots class  $w$  or the removed population versus  $R_0$  and the second plots  $z$  or the infected class versus  $R_0$ . The arrows in the diagram indicate the basins of attraction. If an initial value for a class occurs below the curve of the unstable epidemic state,

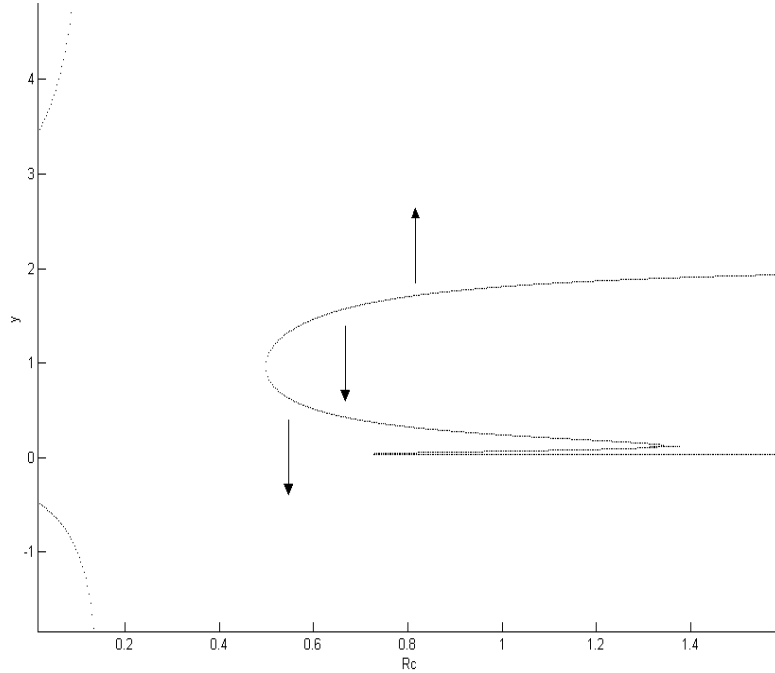

Figure 8: Bifurcation Diagram for the Susceptible Class when  $R_c < 1$  and  $R_0 > 1$

the solutions will be attracted to the ecstasy-free equilibrium and ecstasy use will die out in the population. In the other regions, an epidemic of ecstasy use will arise.

In Figure 10, it is clear that as the epidemic takes place, the recovered class  $w$  decreases. As more individuals use ecstasy, the proportion of the population made up of recovered ecstasy users declines. Hence, the peer pressure from the infected class has a substantial effect on those deciding to stop using ecstasy.

The second bifurcation diagram (Figure 11), demonstrates that an ecstasy epidemic may arise very suddenly when  $R_0 < 1$  and produce a large change in the number of infected during a short time period. Ecstasy use then increases steadily up to and past  $R_0$ . For these parameters, it can also be concluded that the basin of attraction for the ecstasy-free equilibrium is minute and therefore a small number of ecstasy users may lead to an epidemic.

This possibility for an epidemic when  $R_0 < 1$  is significant because it implies that peer pressure can cause a large, sudden increase in ecstasy use, even when rates describing infection are low. A substantial initial population of ecstasy users can cause an epidemic even if the “infectious period” ( $\frac{1}{\gamma+\tau+\mu}$ ) and the “infection rate” ( $\phi$ ) are very small. Furthermore, since  $R_e = .015$ , the initial population of ecstasy users

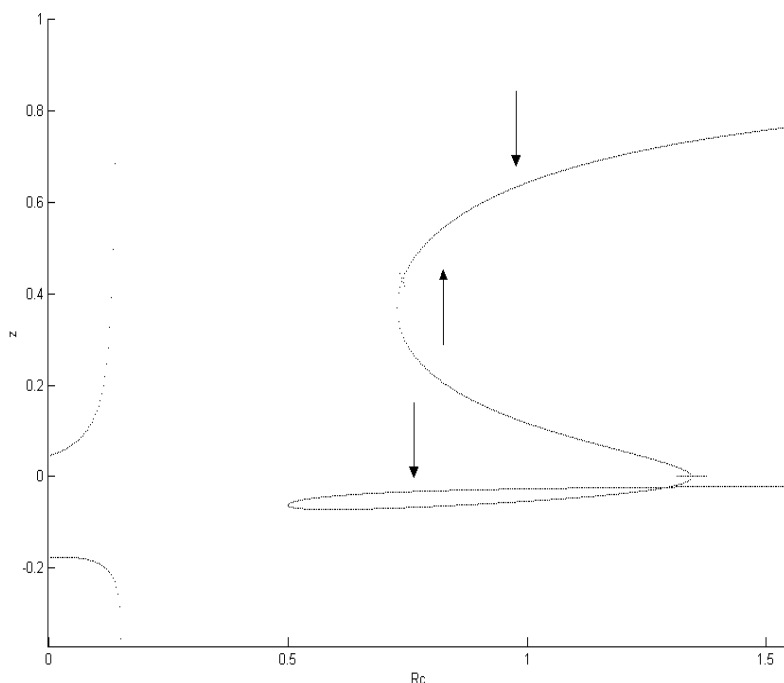

Figure 9: Bifurcation Diagram for the Infected Class when  $R_c < 1$  and  $R_0 > 1$

needed to cause this epidemic is not that considerable.

As  $R_c > 1$ , the non-core population will decline. At the same time, the number of ecstasy users will grow, since  $R_0 > R_e$ . For this simulation, the initial values for the classes are set so that 85 percent of the population is in the non-core class, 8 percent is susceptible, 7 percent is infected and 0 individuals are in the recovered class. Therefore, 7 percent infected is enough to cause an epidemic of ecstasy use when  $R_0 < 1$ . See Figure 7.

Recognize that the parameters values which caused this situation are the exact set that we calculated from research. Although they predict an eventual equilibrium point where approximately 73 percent of the population are ecstasy users, we still believe they are a good indicator of the trend that ecstasy use will follow for the next decade. From these results, we predict that ecstasy use will continue its gradual increase among young people. In addition, these parameters show that if raves go more mainstream, ecstasy use could skyrocket.

Also note that from the previous case of  $R_c < 1$  and  $R_0 > 1$ , all the parameters remain the same while  $\epsilon$  is increased by .001. This tiny change, however, is enough to jump the results from one bifurcation to another. A small augmentation in the re-

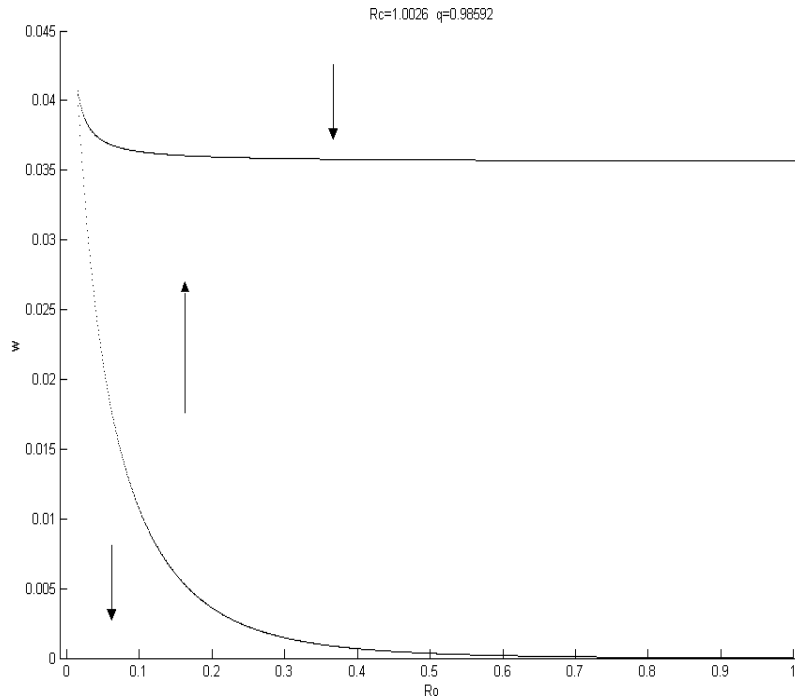

Figure 10: Bifurcation Diagram for the Recovered Class when  $R_c > 1$  and  $R_0 < 1$

recruitment rate creates a base for widespread ecstasy use.  $\epsilon$ , then, is a very important term to watch.

## 6 The Effect of Education

On March 21, 2001, The Drug Enforcement Administration (DEA) of the United States Department of Justice was called in front of the Senate Caucus on International Narcotics Control to give testimony entitled, ‘MDMA and the “Rave” Scene: A Rapidly Growing Threat’. Delivered by, Donnie R. Marshall, administrator of the DEA, he outlined a list of demand reduction strategies, which have been institutionalized by the DEA. Marshall strategies included providing accurate, complete, and current information on the scientific findings and medical effects of ecstasy on the human body through Internet web sites and publications; purchasing Internet “keywords” to ensure anti-drug messages are seen first; working with local, state, and other federal agencies, and nonprofit organizations in an effort to advance drug education; enhancing parental knowledge of raves and ecstasy use and engaging their active participation in education and prevention of drug abuse; and educating high school and college students on the realities of raves and the effects of ecstasy use on the body.

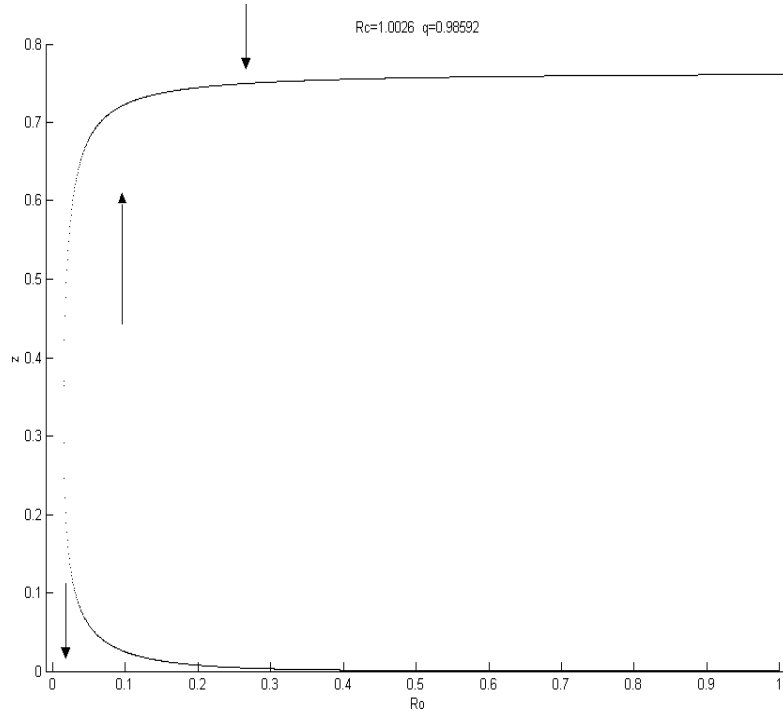

Figure 11: Bifurcation Diagram for the Infected Class when  $R_c > 1$  and  $R_0 < 1$

Here, it is clear that the DEA believes that the best manner in which to halt ecstasy popularity is through knowledge [30].

In order to study the impact of education on ecstasy use in our model, we varied the parameters. We assumed that education would decrease rates leading into the susceptibles ( $\epsilon$ ) and the infected ( $\phi, \alpha$ ) and increase rates moving out from the susceptibles ( $\delta_s$ ), infected ( $\gamma, \tau$ ), and recovered ( $\delta_v$ ).

One intended effect of education would be to keep people from using ecstasy. To look at this effect, we set all the parameters at the estimated values, and then lowered  $\phi$  by an increment of 0.02. We set our initial conditions at 85 percent non-core population, 8 percent susceptibles, 7 percent infected and 0 percent recovered. These estimates are roughly based on the “Monitoring the Future” 1999 study administered by the US Department of Health and Human Services [15]. In order to study the effects of the different parameters, however, we lowered the size of the core population and increased the non-core population.

As  $\phi$  is lowered, the infection rate and the value of  $R_0$  decrease. Therefore if  $\phi$  is small enough, the rate of those who become habitual ecstasy users will decline. From these simulations, however, it is clear that this infection rate must be lowered by a



substantial portion. At these initial values,  $\phi$  must be decreased from 0.275 to 0.195 before ecstasy use stabilizes and then must be lowered even further to 0.175 before there is any clear decline in ecstasy's popularity. Education would reduce this rate that much is highly unlikely, as can be seen from education campaigns directed at other illicit drugs. Therefore, focusing education on the infection rate, is not a good solution to this country's ecstasy problem. See Figure 12 in the appendix.

On the other hand, a reduction of the rate of recruitment into the population that frequents raves and nightclubs ( $\epsilon$ ) has a much greater effect on the number of infected individuals than the infection rate ( $\phi$ ).

Starting from the estimated value of 0.0391, if the value for  $\epsilon$  is cut to 0.0331, the number of infected individuals begins a clear decline. This decrease in  $\epsilon$  is about  $\frac{1}{16}$  the reduction needed of  $\phi$  to have any impact on ecstasy abuse. Additionally, when the value for  $\epsilon$  is decreased, the value of  $R_c$  also decreases. Since  $R_c$  is the threshold at which a change occurs between the susceptible and non-core population, a decrease in  $\epsilon$  leads to a decline in the number of individuals in the susceptible class and an increase in the population of the non-core class. At the estimated parameters,  $R_c$  is barely greater than 1, meaning a small change in  $\epsilon$  will have a large effect on the system. Therefore, education should be focused on keeping young adults from going to raves and nightclubs. See Figure 13 in the appendix.

Increasing  $\delta_s$  has a similar effect as decreasing  $\epsilon$ . This makes sense because,  $\delta_s$  is just the recruitment rate out of the susceptible class into the non-core population.

Here,  $R_c$  becomes less than 1 and the number of individuals in the susceptible and infected classes decrease, while the non-core population increases. Again, this result is another ideal solution to the ecstasy problem. On the other hand, decreasing  $\epsilon$ , seems to be more efficient because the increase of  $\delta_s$  necessary to achieve the same effect as  $\epsilon$  is almost twice as big, something hard to achieve from education. See Figure 14 in the appendix.

$\gamma$  and  $\tau$  are both rates of recovery from the infected class. This removal from ecstasy use can occur either as a result of a decision to stop drug use or a decision to use other drugs instead of ecstasy. The recovery rate,  $\gamma$ , is based on peer pressure, while the rate for  $\tau$  is based on all other factors. Hence, a possible effect of education about the harmful effects of ecstasy might be to increase the values for  $\gamma$  and  $\tau$ .

Enlarging the value of  $\gamma$  or  $\tau$  has the same effect for the same increment of change. Any increase in  $\gamma$  or  $\tau$ , will reduce the value of  $R_0$ , however, only after a change of 0.01 of either parameter will ecstasy use begin to decrease and the non-core population begins to decline. This type of large increase in either rate would be very difficult to achieve via education. Furthermore, neither of the two rates has any effect on the

susceptible class, which is where individuals are very likely to try ecstasy. From these results, focusing education on trying to remove people from the infected class would not be very effective in eradicating ecstasy use. In addition, working to increase  $\gamma$  and  $\tau$  could actually have an adverse effect on the population, as both of these parameters include the rate of moving from ecstasy to other drugs. See Figures 15 and 16 in the appendix.

Although neither  $\alpha$  nor  $\delta_v$  is present in  $R_c$  or  $R_0$ , they both have an effect on the system and so are also studied.

Clearly, when  $\alpha$  (the relapse rate) is decreased enough, the rate at which the infected group grows will also decrease, while the decline of the non-core population slows accordingly. This occurs only after the value for  $\alpha$  is cut in half and so is not a realistic solution when education is the remedy. See Figure 17 in the appendix.

$\delta_v$  is the rate recovered at which individuals go to the non-core class, or discontinue going to raves and nightclubs regularly. Raising the value of  $\delta_v$  results in a decline in the infected class. As the population of recovered people leaving the recovered class increases, the rate of individuals who return to using ecstasy,  $\alpha$ , must drop as well because there are less people to infect.  $\delta_v$ , like  $\alpha$ , requires a large decrease in its value to have a substantial impact on the system. See Figure 18 in the appendix.

Out of all the parameters,  $\epsilon$ , the recruitment rate from the non-core population into the susceptible class, requires the smallest percent change in increment in order to decrease ecstasy use.  $\epsilon$  is followed most closely by  $\delta_s$ . Therefore, any education efforts should be focused not on ecstasy use itself, but instead on the behaviors which lead to taking that first ecstasy pill: the surrounding of a rave or nightclub. Attempts to decrease ecstasy use would be most successful if education programs were aimed at keeping young adults from seeking the entertainment of raves and nightclubs.

## 7 Results for our Model

To obtain a representation of the effects of peer pressure on a population between the ages of 13 and 25, we crafted a deterministic model. We studied this model first analytically and then utilized simulations of parameters estimated from published research to look at the model numerically. In the numerical analysis, we focused on the parameters  $\epsilon$  and  $\phi$  in order to compare the importance of peer-driven recruitment into the susceptible population to peer-driven ecstasy use. Finally, we varied all the parameters so as to predict the most efficient manner of decreasing ecstasy use by means of education.

From the simulations we find four basic situations which can take place. One situation might be that all people between the ages of 13-25 stop attending nightclubs and raves entailing that the non-core class becomes 100 percent of the population. This state arises when the core-free equilibrium is globally asymptotically stable, implying  $R_c < R_0 < 1$  and  $\epsilon < \mu$ . Here, peer pressure from the core population has little effect on the non-core.

Second, the core population could also become zero when  $R_0 > 1$ ,  $R_c < 1$  and  $\epsilon > \mu$ , if  $R_c$  and  $R_0$  are within the boundaries of a backward bifurcation. These boundaries are different for every set of parameter values and are just the values of  $R_c$  and  $R_0$  where multiple endemic equilibria exist. The core-free equilibrium is locally asymptotically stable under this condition, indicating that if there is a small enough initial population of susceptibles, the core classes will cease to exist. On the other hand, if the number of people in the susceptible class is large enough to be within the basin of attraction of the stable endemic equilibrium, the number of people habitually using ecstasy can grow despite decreasing numbers coming into the susceptible class. Here, peer pressure to use ecstasy in the raves and nightclubs is very strong, but the pressure to go to raves isn't. This is enough to maintain high levels of ecstasy prevalence in the population.

Third, when  $1 < R_c < R_0$ , there is one stable endemic equilibrium. Given that  $R_0 > 1$ , the non-core class will decline and the ecstasy class will grow. In this case the pressure to use ecstasy is very strong and is felt by all the classes. However, if  $R_0$  is not too large, then the prevalence of ecstasy is not huge.

Finally, another backward bifurcation describes what transpires when  $R_0 < 1$  and  $R_c > 1$ . Two positive endemic equilibrium exist and the endemic equilibria with the larger infection value along with the ecstasy-free equilibrium are locally asymptotically stable. Depending on the location of the initial population of infected within the basins of attraction of each equilibrium, ecstasy use will either decrease to zero or reach an epidemic state. The existence of a large population of ecstasy users, therefore, creates a lot of pressure on young adults, especially in the susceptible class, to begin using ecstasy. On the other hand, a small population of ecstasy users may exert little influence on the other classes.

Simulations were used to test the effectiveness of education on decreasing the popularity of ecstasy use. In these simulations, we used a set of parameter values, estimated from published research, to describe the current situation of ecstasy use in the United States. These estimated parameters, projected a slow increase in the population of habitual ecstasy users over the next 12 years. Next, to study possible directions that education could use to combat ecstasy use, we varied all the values of parameters (excluding  $\mu$ , the death and aging rate).

From these simulations, we observed that  $\epsilon$ , the recruitment rate from the non-core to the susceptible class, was the most crucial value in causing an ecstasy epidemic. As  $\epsilon$  is in both  $R_c$  and  $R_0$ , it plays a vital role in both the movement into the rave and nightclub culture and the start of ecstasy abuse. Furthermore,  $\epsilon$  (the peer pressure based recruitment rate) is the parameter for which the least decrease in value has the most impact in halting the spread of ecstasy growth.

## 8 Conclusion

On June 3, 1996, The New Yorker Magazine published an article by Malcolm Gladwell entitled “The Tipping Point” [10]. In this commentary, Gladwell describes how epidemic theory is being applied to social problems. He also mentions the concept of a “tipping point” or a threshold at which a stable phenomenon can turn into a social crisis. “Every epidemic has its tipping point, and to fight an epidemic you need to understand what that point is,” writes Gladwell [10].

Unfortunately, from modeling ecstasy we have learned that the situation is not as simple as Gladwell portrays. There are often multiple tipping points, each with complicated conditions, which all must be understood in order to effectively battle a problem such as ecstasy use. Furthermore, abrupt changes can occur from slight variations in initial conditions below the tipping point.

Despite the complexity of our system of equations, we can still learn a lot about ecstasy use from this model. First, peer pressure can drive a sudden increase in ecstasy use, even when threshold conditions seem to predict against this growth. A small group of ecstasy users can also cause an epidemic of ecstasy use if they have enough individuals going to raves and nightclubs to influence. Recruitment into the susceptible class ( $\epsilon$ ), therefore, is the most important factor in determining the extent of ecstasy use. A small increase in  $\epsilon$  can jump a solution from zero infected individuals to an epidemic. Conversely, a small decrease in this term can also solve the problem of ecstasy use in entirety. For this reason, we conclude that most education efforts should be focused at keeping young adults from seeking the excitement of raves and nightclubs. Finally, this model shows once a considerable number of people begin to use ecstasy, decreasing this number is extremely difficult. In other words, peer-driven drug epidemic should be avoided at all costs.

## 9 Future Work

Although all cases for the endemic equilibria were considered numerically, we did not study the cases analytically. We also were unable to establish the existence of the

endemic equilibria in its full generality. Given more time, it would be interesting to try and prove the existence of one or more positive endemic equilibrium. It would also be worthwhile to attempt to find a third basic reproductive number, which at this point we hypothesize to describe the threshold conditions between the infected and recovered class. Additional examination of the bifurcation diagrams is also warranted. Due to lack of time, limited study was possible on these conditions.

Another area to explore would be in the structure of the model itself. There are many other factors, which affect ecstasy use besides peer pressure. A more accurate model might include rates for ecological or family environments, age, race, gender, and behavioral issues. The model could also explore the issue of education and ecstasy more thoroughly by adding education as either a parameter or a class. For example, education could be added as an exponential term or as a constant. Using a modified version of the model to investigate how various methods of education affect ecstasy abuse on an individual level could produce significant results with applications to the cause of reducing this recent “rave craze”.

## 10 Acknowledgments

This study was supported by the following institutions and grants: National Science Foundation (NSF Grant #DMS-9977919); National Security Agency (NSA Grant #MDA 904-00-1-0006); Sloan Foundation: Cornell-Sloan National Pipeline Program in the Mathematical Sciences; and the Office of the Provost of Cornell University.

A special thanks to our advisors Baojun Song and Carlos Castillo-Chavez for their ideas, support and motivation. We would also like to recognize Christopher Kribs-Zaleta and Carlos William Castillo-Garsow for their help and advice. Finally, we would like to thank the MTBI program for giving us the opportunity to be a part of this institute.

## References

- [1] Anderson, Robert N., Kochanek, Kenneth D., and Betty L. Smith. *Deaths: Preliminary Data for 1999*. Division of Vital Statistics, vol. 49, number 3. <http://www.cdc.gov/nchs/data/nvsr/nvsr49/nvsr4903.pdf>. July 26, 2001.
- [2] Beck, Jerome and Marsha Rosenbaum. *Pursuit of Ecstasy*. State University of New York Press, Albany, 1994.

- [3] Castillo-Chavez, C., Dushoff, J., and W. Huang *Backwards Bifurcations and Catastrophe in Simple Models of Fatal Diseases*. Journal of Mathematical Biology, Vol. 36, 227-248. 1998.
- [4] Castillo-Chavez, C., and K.P. Hadeler. *A Core Group Model for Disease Transmission*. Journal of Mathematical Biosciences, Vol. 128, 41-55. 1995.
- [5] Caulkins, J. P., Rydell, C. P., Everingham, S. S., Chiesa, J., and S. Bushmay. *An Ounce of Prevention A Pound of Uncertainty*. Drug Policy Research Center, 1999.
- [6] Coughlin, Eileen V., ed. *Successful Drug and Alcohol Prevention Programs*. Jossey-Bass Publishers: San Francisco, 1994.
- [7] Drug Enforcement Administration. *3,4-Methylenedioxyamphetamin(MDMA, XTC, X, Ecstasy, Adam)*. July 15,2001. <http://www.usdoj.gov/dea/concern/mdma/mdma020700.htm>
- [8] Drug Enforcement Administration. *An Overview of Club Drugs*. July 29, 2001. <http://www.usdoj.gov/dea/pubs/intel/20005intellbrief/pdf>
- [9] Drug Enforcement Administration. *MDMA(Ecstasy)*. July 15, 2001. <http://www.usdoj.gov/dea/concern/mdma/mdma.htm>
- [10] Gladwell, Malcolm. *The Tipping Point*. The New Yorker. June 3, 1996.
- [11] Goplerud, Eric N. *Breaking New Ground For Youth At Risk: Program Summaries*. US Department of Health and Human Services, 1990.
- [12] Greer, George and Tolbert Requa. *Subjective Reports of the Effects of MDMA in a Clinical Setting*. July 16, 2001. <http://www.heffter.org/SUBJREPT.html>
- [13] Herrington, Lois Haight, ed. *White House Conference For A Drug Free America: Final Report* U.S. Government Printing Office, Washington, D.C., 1998.

- [14] Hser, Y., Anglin, M.D., Wickens, T.D., Brecht, M., and J. Homer. *Techniques for the Estimation of Illicit Drug-Use Prevalence: An Overview of Relevant Issues*. US Department of Justice, May 1992.
- [15] Johnston, L.D., O'Malley, P.M., and J.G. Bachman. *Monitoring the Future: National Survey Results On Drug Use 1975-1999; Vol 1-2*. US Department of Health and Human Services, 2000.
- [16] Kribs-Zaleta, Christopher M. *Center Manifolds and Normal Forms in Epidemic Models*. In *Mathematical Approaches for Emerging and Reemerging Infectious Disease Part I: An Introduction to Models, Methods and Theory*. Institute for Mathematics and its Applications, Vol. 125, Springer-Verlag: New York, in press.
- [17] Leshner, Alan I., ed. *Principles of Drug Addiction Treatment: A Research Based Guide*. National Institute on Drug Abuse. <http://www.nida.nih.gov/PODAT/PODATIndex.html>. August 1, 2001.
- [18] Mathias, Robert. *"Ecstasy" Damages the Brain and Impairs Memory in Humans*. National Institute on Drug Abuse, July 15, 2001. <http://www.usdoj.gov/dea/concern/mdma/ecstasy020700.htm>
- [19] National Center on Addiction and Substance Abuse. *CASA Paper: Rural 8th Graders Using Drugs, Smoking, Drinking at Higher Rates than Urban 8th Graders*. January 2000. <http://www.casacolumbia.org/newslettershow.htm?doc>
- [20] National Clearinghouse for Alcohol and Drug Abuse. *Prevention Alert*. July 28, 2000. <http://www.health.org/govpubs/prevalert/v3i25/htm>
- [21] National Institute on Drug Abuse. *Club Drugs: Community Drug Alert Bulletin*. July 15, 2001. <http://165.112/78/61/ClubAlert/ClubDrugAlert/html>
- [22] National Institute on Drug Abuse. *MDMA(Ecstasy)13547/* July 15, 2001. <http://165.112.78.61/infobox/ecstasy.html>
- [23] National Institute on Drug Abuse. *US Senate Caucus on International Narcotics Control*. July 25, 2000. <http://www.drugabuse.gov/testimony17-25-00testimony.html>

- [24] Office of National Drug Control Policy. *Club Drugs*. July 15, 2001. <http://www.whitehousedrugpolicy.gov/drugfact/club/index.html>
- [25] Psychotropics Cornucopica, Inc. *Ecstasy*. July 16, 2001. <http://drugabuse.com/drugs/ecstasy/>
- [26] Strogatz, Steven H. *Nonlinear Dynamics and Chaos* Perseus Books. Massachusetts. 1994.
- [27] Substance Abuse and Mental Health Services Administration. *Ecstasy: What's All the Rave About?* July 15, 2001. <http://www.samhsa.gov/news/content/ecstasywebcast.html>
- [28] Summerville, Eric, Acevedo, Carlos, Gonzalez, Christina, and Karen Rios-Soto. *A Mathematical Model for Lung Cancer: The Effect of Second-Hand Smoke and Education* Studies in Theoretical Biology: A Collection for Undergraduate Research, 521-548, 2000.
- [29] United States Census Bureau. *Population by Age*. July 29, 2001. <http://www.census.gov/population/estimates/nation/intfile2-1.txt>
- [30] United States Department of Justice. *DEA Congressional Testimony*. March 21, 2001. <http://www/usdoj.gov/dea/pubs/cngrtest/ct032101/htm>

## 11 Appendix

The following graphs are used to study the effect of education on the prevalence of ecstasy. Each parameter was varied from the set of estimated parameters shown in Table 2. The graphs then plot the proportion of each class versus time in months.



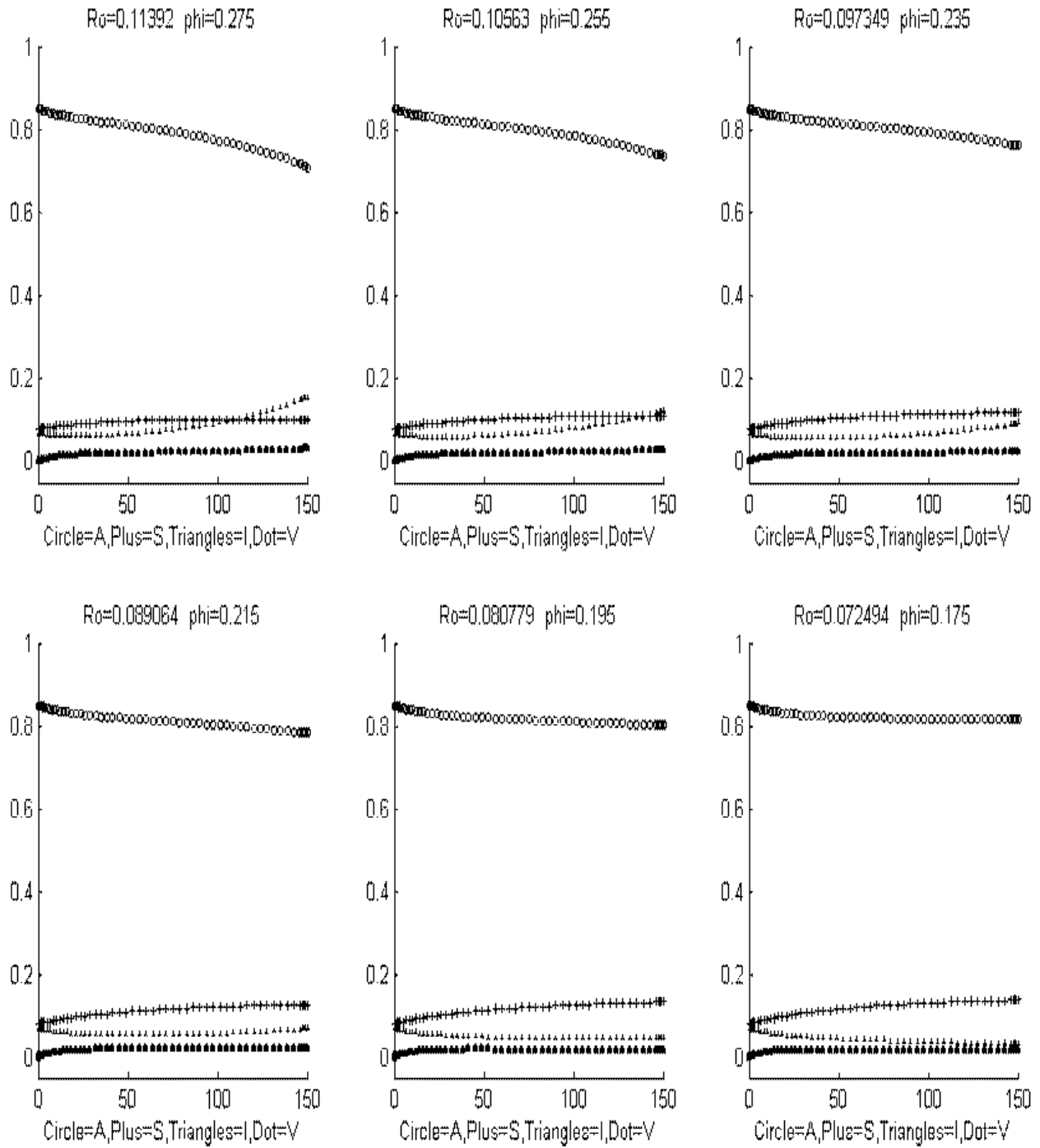

Figure 12: Education and  $\phi$

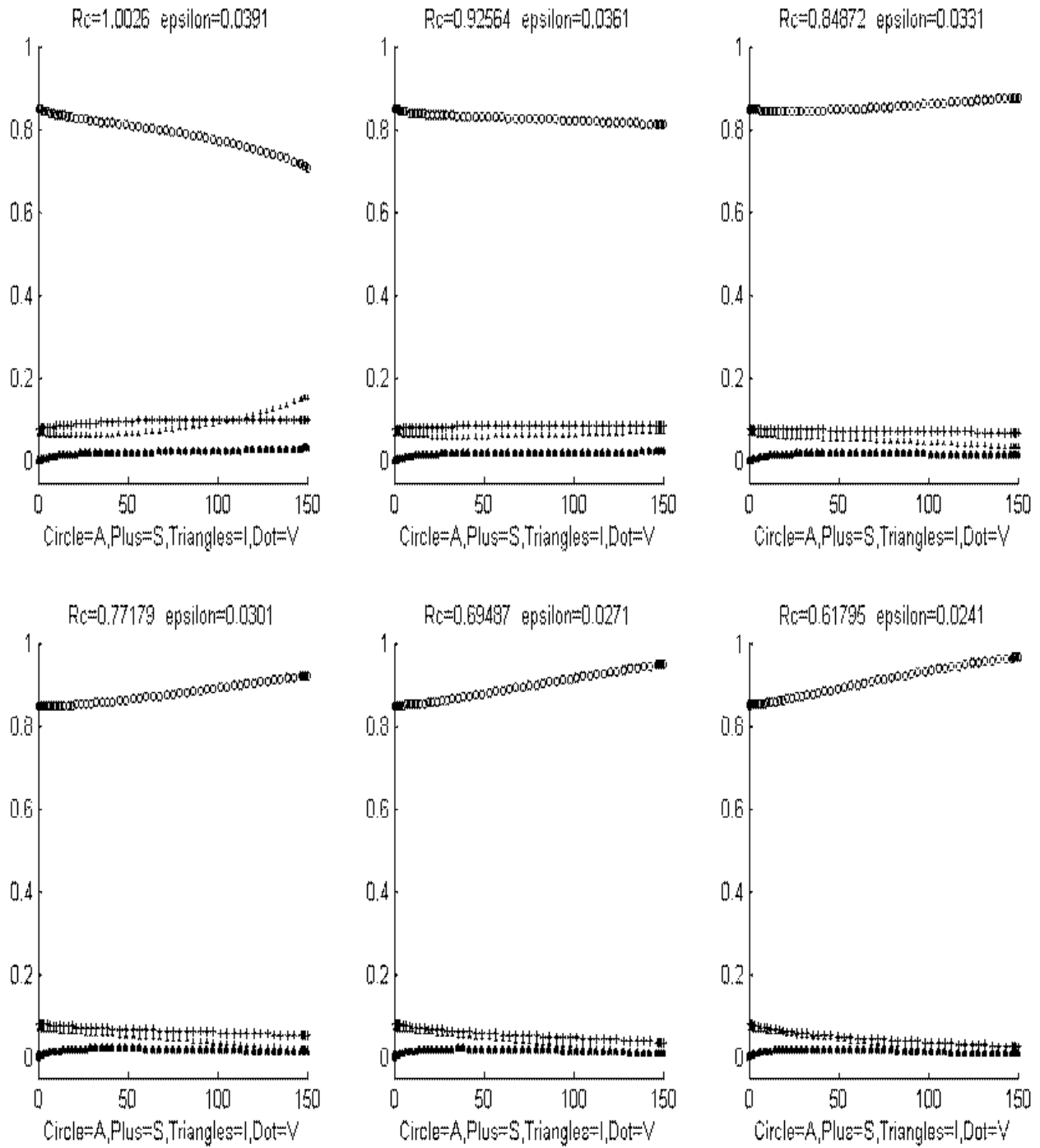

Figure 13: Education and  $\epsilon$

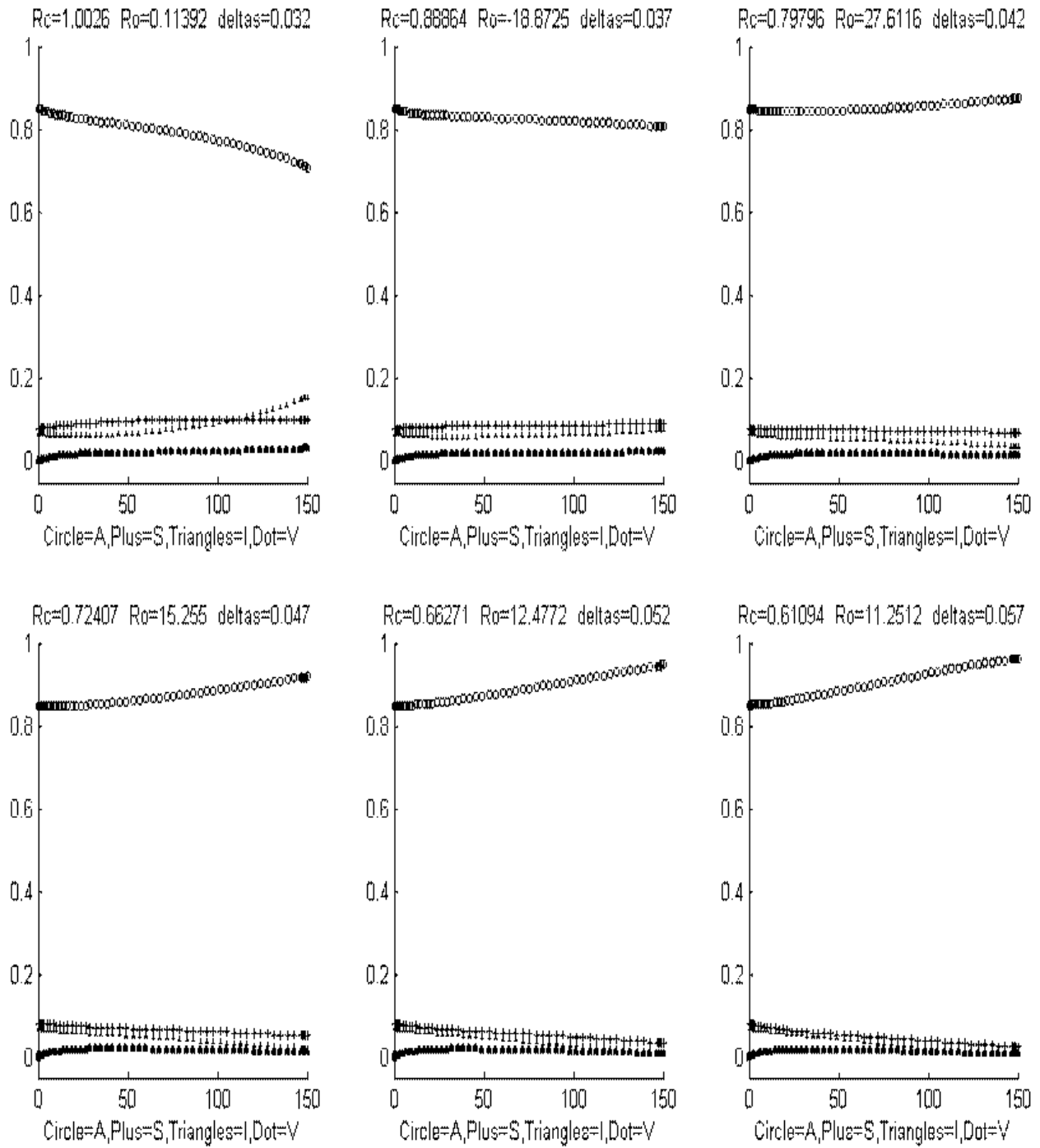

Figure 14: Education and  $\delta_s$

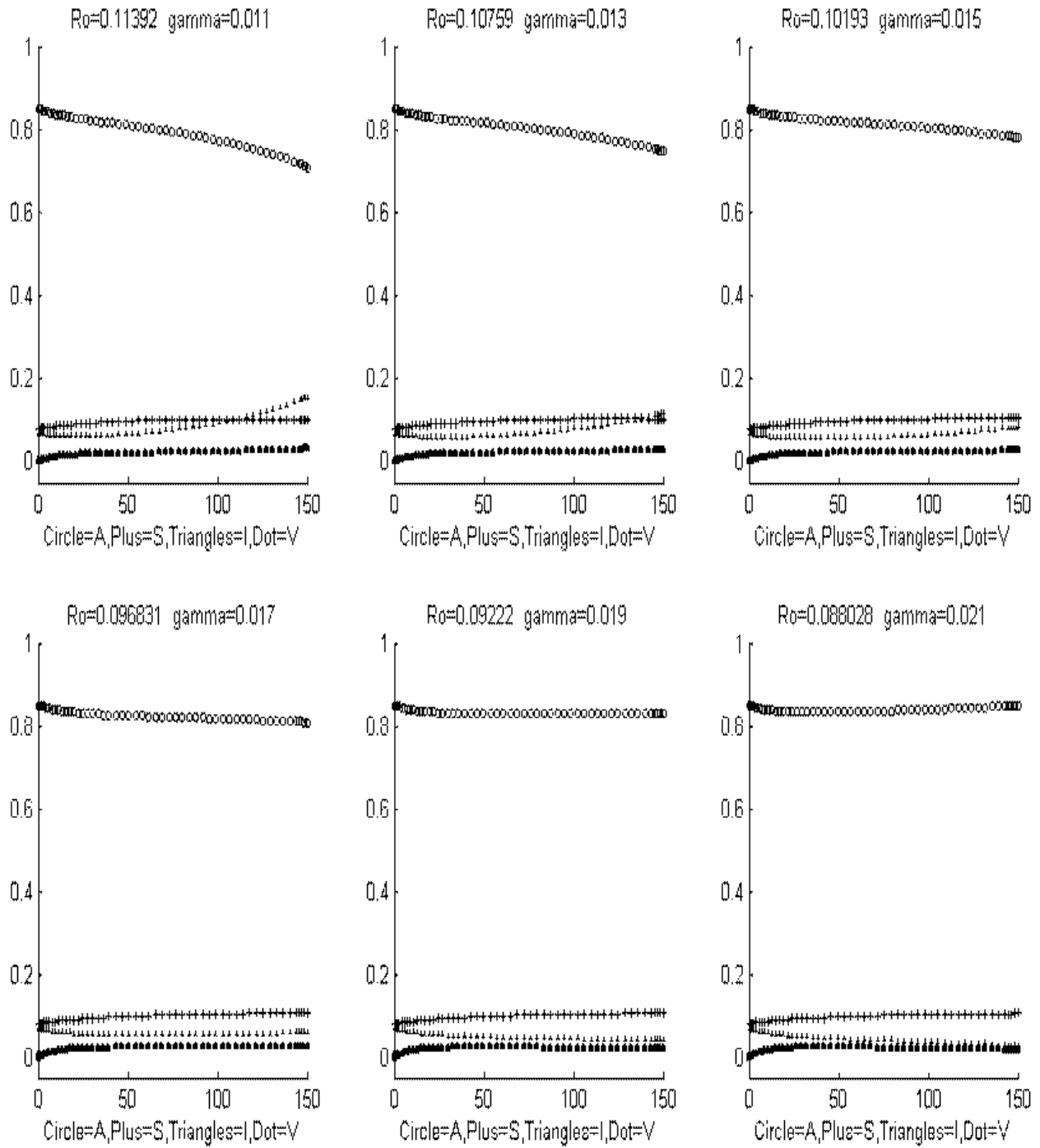

Figure 15: Education and  $\gamma$

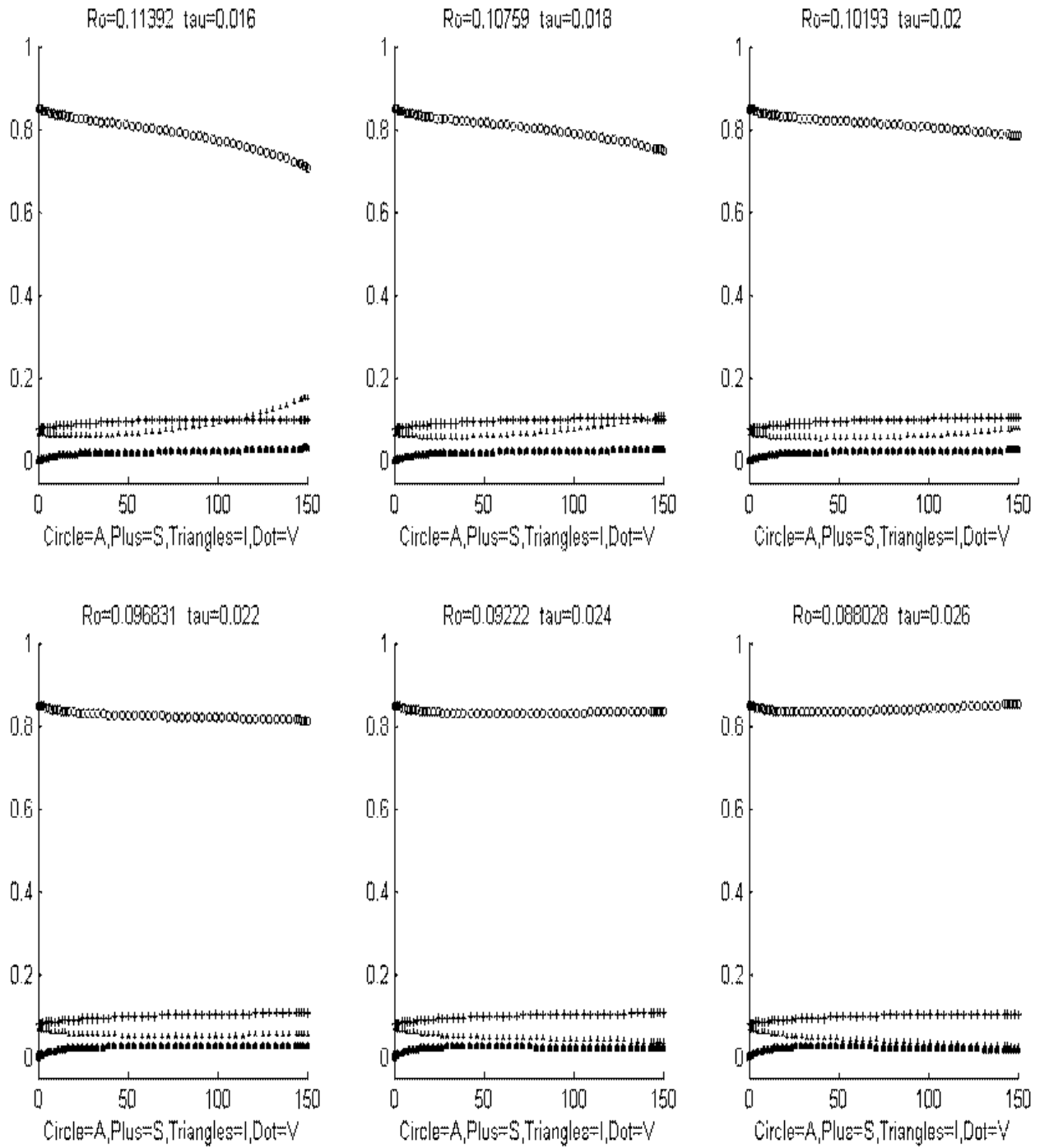

Figure 16: Education and  $\tau$

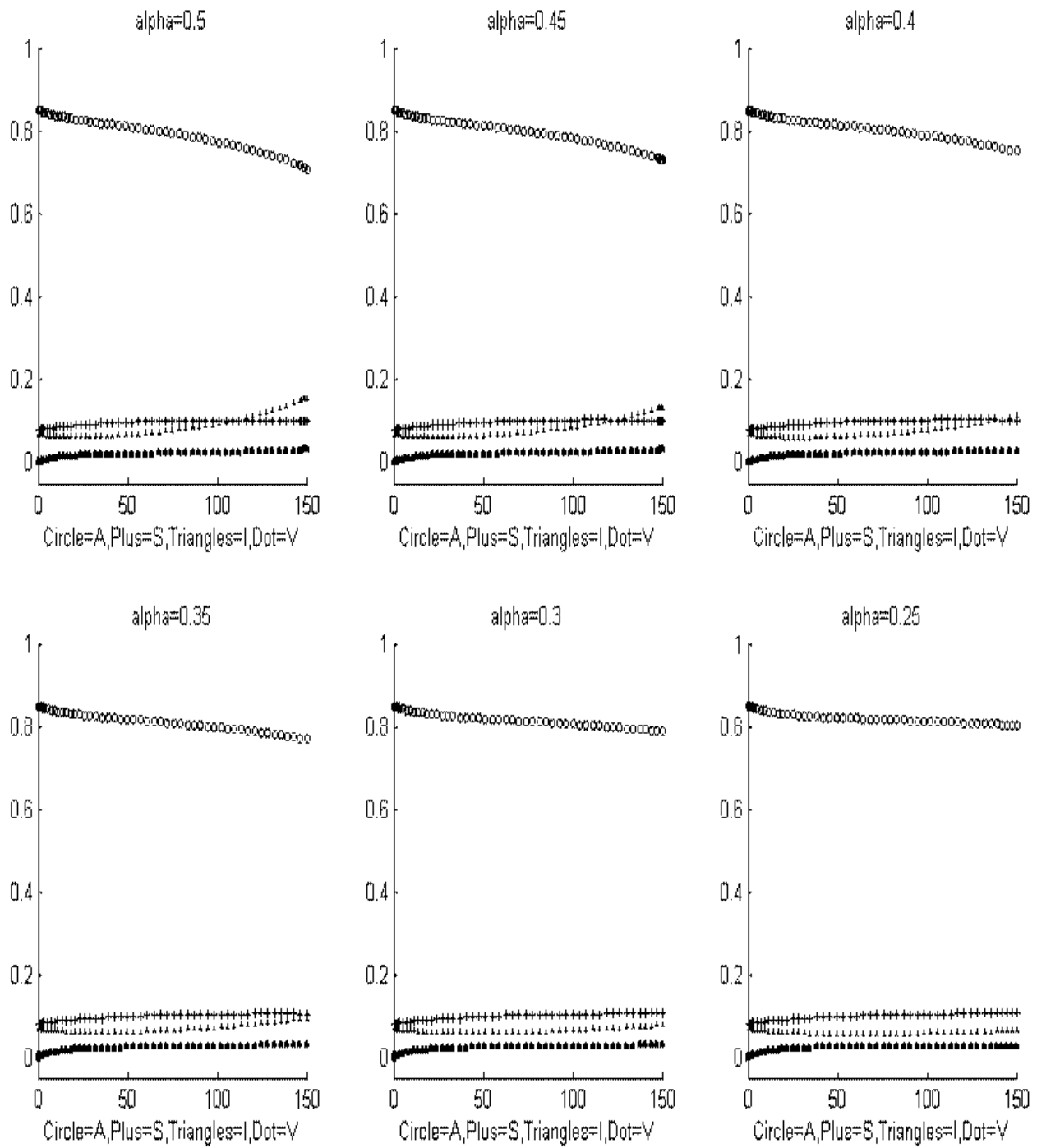

Figure 17: Education and  $\alpha$

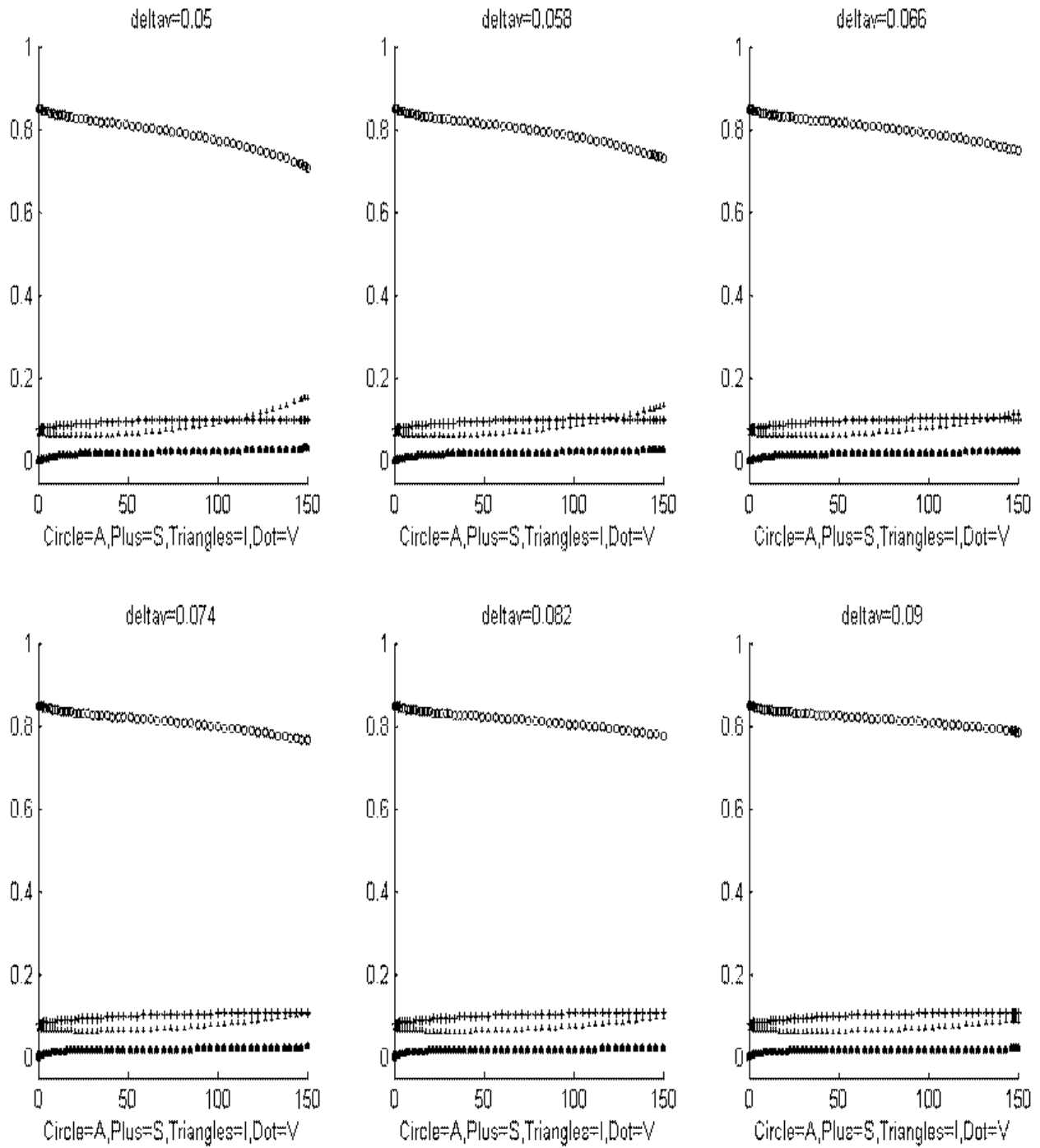

Figure 18: Education and  $\delta_v$

The following MATLAB code is used to generate the graphs used in this study.

```

function dx = connect(t,x,flag,mu,deltav,alpha,epsilon,phi,deltas,gamma,tau)
%Connect is the function describing the system of differential equations
%of x,y,z,w with x=x(1),z=x(2),w=x(3) and y=1-x-z-w.
%
%connect(t,x,flag,mu,deltav,alpha,epsilon,phi,deltas,gamma,tau)

eq1=mu+x(1).*(deltas*(1-x(1)-x(2)-x(3))-epsilon*(1-x(1)-x(3))+x(3)*deltav-mu);
eq2=x(2).*(phi*(1-x(1)-x(2)-x(3))+x(3)*alpha-(gamma*(1-x(2))+tau+mu));
eq3=x(2).*(gamma*(1-x(2))+tau)-x(3).*(x(1)*deltav+mu+x(2)*alpha);
dx=[eq1;eq2;eq3];

function ecstasysingle(t0,tf,v1,v2,v3,x1,x2,x3,mu,deltav,alpha,epsilon,phi,
deltas,gamma,tau)
%ecstasysingle graphs x,y,z,w with respect to time on one plot.
%
%ecstasysingle(t0,tf,v1,v2,v3,x1,x2,x3,mu,deltav,alpha,epsilon,phi,deltas,
gamma,tau)
%t0-intitial value of t
%tf-final value of t
%v1,v2,v3-if true (1) then Rc,q,Ro will be put in the title respectively.
%x1,x2,x3- initial value of x,z,w respectively.

tspan=[t0 tf];
x0=[x1;x2;x3];

figure;
hold on
ecstasyode(x0,tf,tspan,v1,v2,v3,mu,deltav,alpha,epsilon,phi,deltas,gamma,tau);
hold off

function ecstasymultiple(t0,tf,inc,v1,v2,v3,x1,x2,x3,mu,deltav,alpha,epsilon,
phi,deltas,gamma,tau);
%ecstasymultiple graphs x,y,z,w with respect to time on 6 plots with each
%plot having one parameter incremented from the previous one.
%
%ecstasymultiple(t0,tf,inc,v1,v2,v3,x1,x2,x3,mu,deltav,alpha,epsilon,phi,
deltas,gamma,tau);
%t0-intitial value of t
%tf-final value of t
%v1,v2,v3-if true (1) then Rc,q,Ro will be put in the title respectively.
%x1,x2,x3- initial value of x,z,w respectively.

tspan=[t0 tf];
x0=[x1;x2;x3];

figure;
for i=1:6
N=230+i;

```



```

subplot(N)
hold on
ecstasyode(x0,tf,tspan,v1,v2,v3,mu,deltav,alpha,epsilon,phi,deltas,gamma, tau);
hold off
alpha=alpha-inc;
end

function ecstasybifurcation(inti,fini,inci,v,mu,deltav,alpha,epsilon,deltas, gamma,tau);
%ecstasybifurcation will solve F(w) for different values of one parameter
%and plot it. It checks if the values are between 0 and 1 and if it is
%real. It then saves these values in ASCII text format.
%
%ecstasybifurcation(inti,fini,inci,v,mu,deltav,alpha,epsilon,deltas,gamma, tau)
%inti-initial value of phi
%fini-final value of phi
%inci-increment to use for phi
%v-maximum y axis value to graph

numi=(fini-inti)/inci;
rnumi=ceil(numi);

Fz=sym('((gamma+tau-alpha*w-deltav*w*((gamma/phi)-1)-sqrt(((gamma+tau-
alpha*w-deltav*w*((gamma/phi)-1))^2)-4*gamma*w*(deltav*(1-w-((gamma+tau
+mu-alpha*w)/phi))+mu)))/(2*gamma))');
Fy=sym('((gamma+tau+mu-gamma*z-alpha*w)/phi)');
Fw=sym('y*(phi*z+mu)+((1-w-y-z)*(y*(deltas-epsilon)-epsilon*z))');

A=zeros(numi,6);

for i=1:rnumi
A(i,2)=-100;
A(i,3)=-100;
A(i,4)=-100;
A(i,5)=-100;
A(i,5)=-100;
A(i,6)=-100;
end

counti=0;

for i= inti:inci:fini
phi=i
counti=counti+1;
countk=0;
A(counti,1)=i;
z=subs(Fz);
y=subs(Fy);
F2=subs(Fw);
eval('F3=solve(F2);','F3=-100;')
eval('F3=numeric(F3);','F3=-100;')
m=length(F3);
for k=1:m

```

```

if (F3(k)<1) & (F3(k)>0) & (imag(F3(k)) < 0.0001) & (imag(F3(k)) > -0.0001)
countk=countk+1;
A(counti,countk+1)=real(F3(k));
end
end
end

Fz=sym('((gamma+tau-alpha*w-deltav*w*((gamma/phi)-1)+sqrt(((gamma+tau
-alpha*w-deltav*w*((gamma/phi)-1))^2)-4*gamma*w*(deltav*(1-w-((gamma
+tau+mu-alpha*w)/phi))+mu)))/(2*gamma)');

B=zeros(numi,6);

for i=1:rnumi
B(i,2)=-100;
B(i,3)=-100;
B(i,4)=-100;
B(i,5)=-100;
B(i,5)=-100;
B(i,6)=-100;
end

counti=0;

for i= inti:inci:fini
phi=i
counti=counti+1;
countk=0;
B(counti,1)=phi;
z=subs(Fz);
y=subs(Fy);
F2=subs(Fw);
eval('F3=solve(F2);','F3=-100;')
eval('F3=numeric(F3);','F3=-100;')
m=length(F3);
for k=1:m
if (F3(k)<1) & (F3(k)>0) & (imag(F3(k)) < 0.0001) & (imag(F3(k)) > -0.0001)
countk=countk+1;
B(counti,countk+1)=real(F3(k));
end
end
end

figure;
hold on
ecstasybifplot(1,A,B,inti,fini,inci,v,mu,epsilon,deltas,gamma,tau)
hold off

figure;
hold on
ecstasybifplot(0,A,B,inti,fini,inci,v,mu,epsilon,deltas,gamma,tau)

```

```

hold off

A(:, :) B(:, :)

save(['MatA', num2str(now), '.txt'], 'A', '-ASCII');
save(['MatB', num2str(now), '.txt'], 'B', '-ASCII');

function ecstasyfix(Adate, Bdate, inti, fini, inci, v, mu, deltav, alpha,
epsilon, deltas, gamma, tau)
%ecstasyfix will solve F(w) for different values of one parameter
and plot
%it. It checks if the values are between 0 and 1 and if it is real.
It also
%saves the values.
%
%ecstasyfix(Adate, Bdate, inti, fini, inci, v, mu, deltav, alpha, epsilon,
deltas, gamma, tau)
%Adate, Bdate- date on which file containing A and B values,
respectively, was created.
%inti- initial value of phi
%fini- final value of phi
%inci- increment to use for phi
%v- maximum y axis value to graph

A=load(['MatA', Adate, '.txt']);
B=load(['MatB', Bdate, '.txt']);

numi=(fini-inti)/inci;
rnumi=ceil(numi);

Az=zeros(numi,4);
for i=1:rnumi
Az(i,2)=-100;
Az(i,3)=-100;
Az(i,4)=-100;
end

for i= 1:rnumi
phi=A(i,1);
countz=0;
Az(i,1)=phi;
m=size(A,2);
countz=0;
for k=2:m
if (A(i,k)<1) & (A(i,k)>0) & (imag(A(i,k))==0)
w0=A(i,k);
ez=errorfix(0,w0,mu,deltav,alpha,epsilon,phi,deltas,gamma,tau)
if ez(1)
countz=countz+1;
Az(i,countz+1)=real(ez(2));
end
ez=errorfix(1,w0,mu,deltav,alpha,epsilon,phi,deltas,gamma,tau)

```

```

if ez(1)
countz=countz+1;
Az(i,countz+1)=real(ez(2));
end
end
end
end

Az(:,:);
save(['MatAz',num2str(now),'.txt'],'Az','-ASCII');

Bz=zeros(numi,4);

for i=1:rnumi
Bz(i,2)=-100;
Bz(i,3)=-100;
Bz(i,4)=-100;
end

for i= 1:rnumi
phi=B(i,1);
countz=0;
Bz(i,1)=phi;
m=size(B,2);
countz=0;
for k=2:m
if (B(i,k)<1) & (B(i,k)>0) & (imag(B(i,k)) ==0)
w0=B(i,k);
ez=errorfix(1,w0,mu,deltav,alpha,epsilon,phi,deltas,gamma,tau)
if ez(1)
countz=countz+1;
Bz(i,countz+1)=real(ez(2));
end
ez=errorfix(0,w0,mu,deltav,alpha,epsilon,phi,deltas,gamma,tau)
if ez(1)
countz=countz+1;
Bz(i,countz+1)=real(ez(2));
end
end
end
end

figure;
hold on;
ecstasybifplot(0,Az,Bz,inti,fini,inci,v,mu,epsilon,deltas,gamma,tau)

hold off;

figure;
hold on;
ecstasybifplot(1,Az,Bz,inti,fini,inci,v,mu,epsilon,deltas,gamma,tau)

```

```

save(['MatBz',num2str(now),'.txt'],'Bz','-ASCII');

function ecstasyode(x0,tf,tspan,v1,v2,v3,mu,deltav,alpha,epsilon,phi,
deltas,gamma,tau)
%ecstasyode solves 'connect' and plots it.
%
%ecstasyode(x0,tf,tspan,v1,v2,v3,mu,deltav,alpha,epsilon,phi,deltas,
gamma,tau)
%x0-initial value of x
%tf-final value of t
%tspan-the span of time that is considered
%v1,v2,v3-if true (1) then Rc,q,Ro will be put in the title
respectively.

axis([0 tf -0.05 1]);

[t,x]=ode45('connect',tspan,x0,[],mu,deltav,alpha,epsilon,phi,deltas,
gamma,tau);

plot(t,x(:,1),'o','MarkerSize',2);
plot(t,1-x(:,1)-x(:,2)-x(:,3),'+', 'LineWidth',1,'MarkerSize',3);
plot(t,x(:,2),'^','MarkerSize',2);
plot(t,x(:,3),'.','MarkerSize',5);

xlabel('Circle=A,Plus=S,Triangles=I,Dot=V');

Rc=epsilon/(mu+deltas);
q=mu/(epsilon-deltas);
Ro=phi*(1-q)/(mu+tau+gamma);

if v1
str=['Rc=',num2str(Rc),' '];
end
if v2
str=[str,'q=',num2str(q),' '];
end
if v3
str=[str,'Ro=',num2str(Ro),' '];
end

title(str);

function ecstasybifplot(flag,A,B,inti,fini,inci,v,mu,epsilon,deltas,
gamma,tau)
%ecstasybifplot will plot the matrices A and B which are the
bifurcation
%diagram values.
%
%ecstasybifplot(flag,A,B,inti,fini,inci,v,mu,epsilon,phi,deltas,
gamma,tau)
%flag-If true (1) x axis is phi, if false(0) then the axis is Ro
%inti-intitial value of phi

```

```

%fini-final value of phi
%inci-increment to use for phi
%v-maximum y axis value to graph

rnum=(fini-inti)/inci;

if flag
q=mu/(epsilon-deltas);
Ro=(1-q)/(mu+tau+gamma);
intr=inti*Ro;
incr=inci*Ro;
finr=fini*Ro;
xlabel('Ro');
ylabel('z');
else
intr=inti;
incr=inci;
finr=fini;
xlabel('phi');
ylabel('z');
end

s=linspace(inti,fini,rnum);
axis([intr finr 0 v]);
p=size(A,2);
for i=2:p
plot(s, A(:,i),'o','color',[1 1 1],'MarkerSize',1,'MarkerFaceColor',
,[0 0 0],'MarkerEdgeColor',[0 0 0]);
end

p=size(B,2);
for i=2:p
plot(s, B(:,i),'o','color',[1 1 1],'MarkerSize',1,'MarkerFaceColor',
,[0 0 0],'MarkerEdgeColor',[0 0 0]);
end

function ezpass=errorfix(s,w0,mu,deltav,alpha,epsilon,phi,deltas,gamma,tau)
%errorfix finds the value of z given w and the parameters and checks
if it
%satisfies F(w)=0 and the original equations.
%
%errorfix(s,w0,mu,deltav,alpha,epsilon,phi,deltas,gamma,tau)
%s-If true then uses z with +sqrt, if false(0) then uses z with -sqrt
%w0-value of w

if s
z2=((gamma+tau-alpha*w0-deltav*w0*((gamma/phi)-1)+sqrt(((gamma+tau-
alpha*w0-deltav*w0*((gamma/phi)-1))^2-4*gamma*w0*(deltav*(1-w0-((gamma
+tau+mu-alpha*w0)/phi))+mu)))/(2*gamma));
else
z2=((gamma+tau-alpha*w0-deltav*w0*((gamma/phi)-1)-sqrt(((gamma+tau-
alpha*w0-deltav*w0*((gamma/phi)-1))^2-4*gamma*w0*(deltav*(1-w0-((gamma

```

```

+tau+mu-alpha*w0)/phi))+mu)))/(2*gamma));
end

y2=((gamma+tau+mu-gamma*z2-alpha*w0)/phi);
sum=1-z2-y2-w0;
Fw=y2*(phi*z2+mu)+((1-w0-y2-z2)*(y2*(deltas-epsilon)-epsilon*z2));
e1=phi*y2+gamma*z2+alpha*w0-gamma-tau-mu;
e2=mu*(z2+w0)+deltav*w0*(1-y2-z2-w0)-phi*z2*y2;
e3=epsilon*sum*(y2+z2)-y2*(phi*z2+deltas*sum+mu);

c=0;
if (z2<1) & (z2>0) & (imag(z2)==0) & (Fw<.0001) & (e1<.0001) &
(e2<.0001) & (e3<.0001)
c=1;
end

ezpass=[c;z2];

```