

# Critical Response Models for Foot-and-Mouth Disease Epidemics

Johnsie Ortiz\*   Manuel A. Rivera†   Daniel Rubin‡   Israel Ruíz§  
Carlos M. Hernández¶   Carlos Castillo-Chavez||

August 6, 2002

## Abstract

In this work, we analyze the spread of Foot-and-Mouth Disease (FMD) in Uruguay using three different tools: a deterministic model, a continuous-time Markov chain stochastic model and an explicit stochastic simulation model. The deterministic model, a system of nonlinear ordinary differential equations, uses the cow as the basic epidemiological unit. We compute the basic reproductive number,  $R_0$ , for a system that differentiates between beef and dairy populations of cows.  $R_0$  is used to study FMD persistence and control. In the stochastic model, the basic epidemiological unit is the farm. The impact of a policy that quarantines farms is explored. The conditions for quarantine rate that eradicate the disease are computed. The stochastic simulation model takes into account the coordinates of farms, the traffic between farms, and the type of farm (dairy or beef). Simulations of the FMD epidemic are based on data from Uruguay, where we try to predict the regions to quarantine for a viable national control measure in response to an index case.

---

\*Universidad de Puerto Rico-Cayey, Cayey, Puerto Rico(aprendan@hotmail.com).

†Universidad Metropolitana, San Juan, Puerto Rico(mrivejime@hotmail.com).

‡Stanford University, California, USA(drubin@stanford.edu).

§Universidad de Puerto Rico-Cayey, Cayey, Puerto Rico(caronteilrr@hotmail.com).

¶Universidad de Colima(cmoises@mcdm.net).

||Cornell University, New York, USA(cc32@cornell.edu).

# 1 Introduction

FMD is caused by a small (23-nm) single-stranded RNA virus, and is a member of the genus *Aphovirus* in the family *Picornaviridae*. This disease is not harmful to humans, but can affect cattle, sheep, goats, swine, and other animals. Although it is not usually lethal, FMD causes fever, lesions, and erosions on the tongue, lips, and between hooves in infected animals. It leaves cattle debilitated for several months, causing severe losses in meat and milk production, and annually could cost 50 billion US dollars in lost productivity and worldwide export restrictions. It is for this reason that an FMD epidemic can create severe economic consequences to infected regions, and it is for this reason that this work focuses on the spread of FMD in populations of cattle in Uruguay.

The disease can spread very rapidly, and can be transmitted by infected animals as well as through contact with contaminated vehicles, animal holding facilities, food, water, clothes, and footwear. Although there are vaccines available for FMD, a preventative vaccination policy is useless because immunity to one type of the virus does not protect against other strains of the virus (there are at least seven types, with many subtypes) and vaccines are only effective for one year. Efforts to prevent FMD spread can include regulatory measures against countries with FMD outbreaks, quarantining infected areas, and massive slaughtering of infected animals.

Even strict regulatory measures are sometimes insufficient to control the FMD spread, as evidenced by a recent Uruguayan epidemic. In this epidemic an index case appeared on April 23, 2001 and quarantine and slaughter policies were quickly implemented in the regions surrounding the source of infection. These policies were insufficient to contain the disease, and Uruguay resorted to an expensive mass vaccination program that eventually ended the epidemic. The outbreak caused huge economic losses because beef and dairy exports to the United States were halted. The goal of this work is to mathematically model how FMD spread depends on control measures, and to formulate theoretical disease response strategies that could contain future epidemics.

We present three approaches to model the FMD spread: a deterministic model, a stochastic model, and a computer simulation program. In moving between these models we make different tradeoffs concerning how much mathematical tractability to give up for biologically realistic representations. In the deterministic model we derive an expression for the basic reproductive number for the FMD epidemic, and we determine how a more efficient screening process could reduce the disease impact. With the stochastic model, we formulate the minimum rate at which quarantine of farms is necessary to control FMD. This rate could be useful to policymakers who could more effectively eliminate the disease without spending too much money. The computer simulation model solves the practical problem of partitioning Uruguay into regions where stamping out could be an effective enough response to an outbreak so that national vaccination might be unnecessary. The three models above illustrate

how the FMD epidemic can be tackled by determining how much analytical tractability of a model to give up in order to incorporate realistic epidemiological dynamics.

## 2 Methodology

### 2.1 Deterministic Model

This model considers two coupled patches representing a dairy farm and a beef farm. Let,  $S_i$ ,  $L_i$ ,  $I_i$ ,  $Q_i$ , and  $Q_i^L$  represent the susceptible, latent, infectious, quarantine susceptible, and quarantine latent classes of the system for the  $i$ th patch, respectively. Transmission is modeled based on the following nonlinear system of ordinary differential equations:

for *DairyPatch*:

$$\frac{dS_1}{dt} = \tau_1 - \beta_1 I_1 \frac{S_1}{N_1} - \alpha S_1 - \mu_1 S_1 \quad (1)$$

$$\frac{dL_1}{dt} = \beta_1 I_1 \frac{S_1}{N_1} - \gamma L_1 - \alpha L_1 - \mu_1 L_1 + \delta L_2 - \epsilon L_1 \quad (2)$$

$$\frac{dI_1}{dt} = \gamma L_1 - (\mu_1 + d) I_1 \quad (3)$$

$$\frac{dQ_1}{dt} = \alpha S_1 - \mu_1 Q_1 \quad (4)$$

$$\frac{dQ_1^L}{dt} = \alpha L_1 - (\mu_1 + d) Q_1^L \quad (5)$$

$$\frac{dN_1}{dt} = \tau_1 - (Q_1 + Q_1^L + S_1 + L_1 + I_1) \mu_1 - (I_1 + Q_1^L) d + \delta L_2 - \epsilon L_1 \quad (6)$$

for *BeefPatch*:

$$\frac{dS_2}{dt} = \tau_2 - \beta_2 I_2 \frac{S_2}{N_2} - \alpha S_2 - \mu_2 S_2 \quad (7)$$

$$\frac{dL_2}{dt} = \beta_2 I_2 \frac{S_2}{N_2} - \gamma L_2 - \alpha L_2 - \mu_2 L_2 - \delta L_2 + \epsilon L_1 \quad (8)$$

$$\frac{dI_2}{dt} = \gamma L_2 - (\mu_2 + d) I_2 \quad (9)$$

$$\frac{dQ_2}{dt} = \alpha S_2 - \mu_2 Q_2 \quad (10)$$

$$\frac{dQ_2^L}{dt} = \alpha L_2 - (\mu_2 + d) Q_2^L \quad (11)$$

$$\frac{dN_2}{dt} = \tau_2 - (Q_2 + Q_2^L + S_2 + L_2 + I_2)\mu_2 - (I_2 + Q_2^L)d - \delta L_2 + \epsilon L_1 \quad (12)$$

where  $N_i$  gives us the population size in the patches and is given by the following equations:

$$\begin{aligned} N_1 &= S_1 + L_1 + I_1 + Q_1 + Q_1^L \\ N_2 &= S_2 + L_2 + I_2 + Q_2 + Q_2^L \end{aligned}$$

for  $i = 1$  in the dairy patch, and  $i = 2$  in the beef patch  
 Here the coupling per-capita rates  $\epsilon$  and  $\delta$  are used just to phenomenologically connect both populations. There are more realistic methods for doing this but the resulting model complexity does not seem to provide additional insight.

Table 1: List of Parameters

Parameters	Description
$\mu_1$	natural mortality rate in the dairy patch
$\mu_2$	natural mortality rate in the beef patch
$\tau_1$	recruitment rate of the dairy patch
$\tau_2$	recruitment rate of the beef patch
$\beta_1$	contact rate between infectious and susceptible farms in the dairy patch
$\beta_2$	contact rate between infectious and susceptible farms in the beef patch
$\gamma_1$	rate at which latent farms show symptoms in the dairy patch
$\gamma_2$	rate at which latent farms show symptoms in the beef patch
$d$	rate at which farms are removed from the system
$\epsilon$	coupling rate from the dairy patch to the beef patch
$\delta$	coupling rate from the beef patch to the dairy patch
$\alpha$	screening and quarantine rate for both patches

### 2.1.1 The Model

We will study how to control the spread of the disease in animal to animal transmission. By solving the ODE system, we hope to calculate  $R_0$ , needed for a biological interpretation, and identify strategies for controlling the FMD epidemic. We assume a migration rate  $\delta$  from dairy to beef cows and a migration rate  $\epsilon$  from beef to dairy cows. Because this is not likely to happen in real life, rates  $\delta$  and  $\epsilon$  are very small. We assume that quarantined cows cannot get infected and cannot infect other cows.

In equations (1) and (7) modeling the rate of change in the susceptible class per day,  $\tau_i$  is the number of new dairy and beef cows per day. The term  $\beta_i I_i \frac{S_i}{N_i}$  is the number of contacts in a day between infected and susceptible cows. The parameter  $\alpha$  represents the rate at which cows are “screened” and quarantined in a day.

Equations (2) and (8) model the rate of change of the latent class per day. In this class, cows are infected but not infectious, and they move to the infectious class at rate  $\gamma$ . Because latent cows show no symptoms, they cannot be distinguished from susceptible cattle, and are also quarantined at rate  $\alpha$ .

Equations (3) and (9) model the rate of change in the infected class. Infected cows can be symptomatic, thereby causing the disease spread. One FMD control method is to kill infected cattle at per-capita rate  $d$ .

The decision of whose to quarantine the cows will be based on screening for latent infections. Equations (4) and (10), we show the rate of change in the quarantined susceptible population. Equations (5) and (11) model the change in the quarantined latent class. The cows reach that class and stay there until they are killed at the same rate as cattle in the infectious class. The difference is that members of this class cannot infect the susceptible cows, unlike the infectious class. The rate at which a country can test and quarantine is given by  $\alpha$ . Finally, the classes have a natural death rate of  $\mu_1$  for dairy cows and  $\mu_2$  for beef cows. Also, equations (6) and (12) show the change in the number of dairy and beef cows per day. The population is obviously not constant (a common situation) for herds due to FMD control practices.

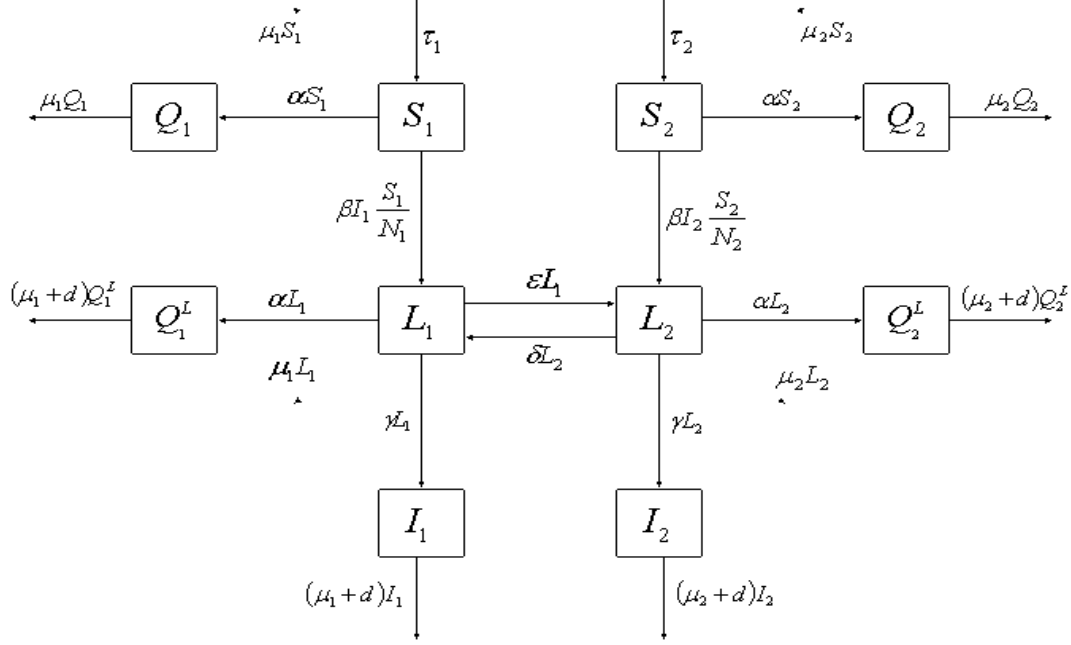

Figure 1: Deterministic FMD Model

### 2.1.2 Model Reduction

In order to simplify the process of calculating the disease free equilibria and the basic reproductive number ( $R_0$ ) we set equations (3) and (9)=0

This leads to:

$$I_1 = \gamma \frac{L_1}{\mu_1 + d} \text{ and } I_2 = \gamma \frac{L_2}{\mu_2 + d}$$

After substituting  $I_1$  and  $I_2$ , the following system is obtained for the *DairyPatch*:

$$\frac{dS_1}{dt} = \tau_1 - \beta_1 L_1 \frac{\gamma}{\mu_1 + d} \frac{S_1}{N_1} - \alpha + \mu_1 S_1 \quad (13)$$

$$\frac{dL_1}{dt} = \frac{\gamma}{\mu_1 + d} \beta_1 L_1 \frac{S_1}{N_1} - (\mu_1 + \gamma + \alpha + \epsilon) L_1 + \delta L_2 \quad (14)$$

$$\frac{dQ_1}{dt} = \alpha S_1 - \mu_1 Q_1 \quad (15)$$

$$\frac{dQ_1^L}{dt} = \alpha L_1 - (\mu_1 + d) Q_1^L \quad (16)$$

Likewise, the following system of equations is obtained for the *BeefPatch*:

$$\frac{dS_2}{dt} = \tau_2 - \beta_2 L_2 \frac{\gamma}{\mu_2 + d} \frac{S_2}{N_2} - \alpha + \mu_2 S_2 \quad (17)$$

$$\frac{dL_2}{dt} = \frac{\gamma}{\mu_2 + d} \beta_2 L_2 \frac{S_2}{N_2} - (\mu_2 + \gamma + \alpha + \delta) L_2 + \epsilon L_1 \quad (18)$$

$$\frac{dQ_2}{dt} = \alpha S_2 - \mu_2 Q_2 \quad (19)$$

$$\frac{dQ_2^L}{dt} = \alpha L_2 - (\mu_2 + d) Q_2^L \quad (20)$$

### 2.1.3 Equilibrium Points

The infection-free state has the coordinates  $I_1^* = I_2^* = L_1^* = L_2^* = Q_1^{L*} = Q_2^{L*} = 0$

and,

$$S_1^* = \frac{\tau_1}{\mu_1 + \alpha}$$

$$S_2^* = \frac{\tau_2}{\mu_2 + \alpha}$$

$$Q_1^* = \frac{\alpha}{\mu_1}$$

$$Q_2^* = \frac{\alpha}{\mu_2}$$

### 2.1.4 Stability of the equilibrium points

The stability of the infection-free equilibrium points is determined by the eigenvalues of the Jacobian matrix at  $S_1^*, S_2^*, Q_1^*, Q_2^*, 0, 0, 0, 0$ . We also introduce the following notation.

$$C_1 = \frac{\gamma \beta_1 S_1}{(\mu_1 + d)(S_1 + Q_1)}$$

$$\Delta_1 = \mu_1 + \gamma + \alpha + \epsilon$$

$$C_2 = \frac{\gamma \beta_2 S_2}{(\mu_2 + d)(S_2 + Q_2)}$$

$$\Delta_2 = \mu_2 + \gamma + \alpha + \epsilon$$

Then the Jacobian at this equilibrium becomes:

$$J = \begin{bmatrix} -(\mu_1 + \alpha) & 0 & 0 & 0 & \frac{-\beta_1 S_1}{(\mu_1 + d)(S_1 + Q_1)} & 0 & 0 & 0 \\ 0 & -(\mu_2 + \alpha) & 0 & 0 & 0 & \frac{\gamma}{\mu_2 + d} & 0 & 0 \\ \alpha & 0 & -\mu_1 & 0 & 0 & 0 & 0 & 0 \\ 0 & \alpha & 0 & -\mu_2 & 0 & 0 & 0 & 0 \\ 0 & 0 & 0 & 0 & C_1 - \Delta_1 & \delta & 0 & 0 \\ 0 & 0 & 0 & 0 & \epsilon & C_2 - \Delta_2 & 0 & 0 \\ 0 & 0 & 0 & 0 & \alpha & 0 & -(\mu_1 + d) & 0 \\ 0 & 0 & 0 & 0 & 0 & \alpha & 0 & -(\mu_2 + d) \end{bmatrix}$$

:The six negative eigenvalues are  
*eigenvalues* =  $-(\mu_1 + d), -(\mu_2 + d), -\mu_1, -\mu_2, -(\mu_1 + d), -(\mu_2 + d)$

Additional eigenvalues are computed based on the reduced Jacobian below:

$$J = \begin{pmatrix} C_1 - \Delta_1 & \delta \\ \epsilon & C_2 - \Delta_2 \end{pmatrix}$$

The characteristic equation is:

$$\lambda^2 - [(C_1 - \Delta_1) + (C_2 - \Delta_2)]\lambda + (C_1 - \Delta_1)(C_2 - \Delta_2) - \delta\epsilon$$

The disease-free equilibrium is if the trace is negative and the determinant positive (unstable otherwise).

$$\begin{aligned} (C_1 - \Delta_1)(C_2 - \Delta_2) &> 0 \\ (C_1 - \Delta_1) + (C_2 - \Delta_2) &< 0 \\ (C_1 - \Delta_1)(C_2 - \Delta_2) &> \delta\epsilon \\ C_1 - \Delta_1 &= \max\{\delta, \epsilon\} \\ C_2 - \Delta_2 &= \max\{\delta, \epsilon\} \end{aligned}$$

We define

$$R_0^i = \frac{C_i}{\Delta_i}$$

as the reproductive number in patch i.

If both  $R_0^i < 1$  then the infectious-free is stable otherwise is unstable and

$$R_0 \equiv \max\{R_0^i\}$$

for  $i=1,2$ .



Substituting, we get (Explicit expression):

$$R_0^i = \beta_i \frac{1}{\mu_i + \delta} \frac{S_i^*}{S_i + Q_i^*} \frac{\gamma}{\mu_i + \gamma + \alpha + \phi}$$

where,

$\beta_i$  = contact rate in patch i

$\frac{1}{\mu_i + \delta}$  = average infectious period in patch i

$\frac{S_i^*}{S_i + Q_i^*}$  = proportion of susceptible in patch i

$\frac{\gamma}{\mu_i + \gamma + \alpha + \phi_i}$  = proportion of cows that become infected in patch i

$\phi = \epsilon$  if  $i = 1$  or  $\delta$  if  $i = 2$

We clearly can see that if  $\alpha$  is large enough, the disease will not spread. As  $\alpha$  increases  $\frac{S_i^*}{S_i + Q_i^*}$  decreases, as well the proportion of cows that become infected. Consequently, screening may be useful in control of an FMD epidemic because the disease could not spread fast enough to become endemic if  $\alpha$  were increased to the point where  $R_0 < 1$ . In conclusion, an effective method of screening may save considerable time and money in future FMD outbreaks.

### 2.1.5 Stochastic Model

In this section we develop a stochastic model for the FMD epidemics. The goal is to derive a mathematical expression for an “effective” quarantine rate. Such a rate would help policy decision makers who must decide how stringent the controls should be on animal movement, human transportation, and agricultural commerce during an FMD outbreak. The basic epidemiological units in the model are farms that can be susceptible ( $S$ ), latent ( $L$ ), infectious ( $I$ ), quarantined ( $Q$ ) or removed ( $R$ ). A susceptible farm is one in which all livestock do not have the virus but can potentially become infected. A latent farm contains asymptomatic livestock that carry the virus but cannot transmit it. Infectious farms contain animals that passed through the latent state and are now infected. Quarantined farms are farms that have restricted contact with other farms, and are thus less prone to becoming infected. In our model, quarantined farms have a reduced contact rate with infectious farms by a fraction  $f$ , and we assume that an infectious quarantined farm cannot infect other farms. Removed farms are farms where all livestock were found in the infectious state and were subsequently slaughtered. Quarantining starts to take place in both susceptible and latent farms because in the latter, farmers are not aware of the disease presence.

The parameters in our model are presented in Table 2 below. All rates are taken to be parameters of exponentially distributed times for state transitions, and the model assumes random mixing:

Table 2: List of Parameters

Parameters	Description
$\lambda$	contact rate, i.e, the rate at which a farm sends biological, active material to other farms
$\theta$	quarantine rate, i.e., the rate at which farmers become aware of the disease and start applying restrictions to traffic in and out their farms
$\gamma^{-1}$	average duration of the latent state
$\alpha$	removal rate, i.e., the rate at which a farm is removed once it is found to be infectious
$f$	fraction in which the contact rate is reduced for quarantined farms, $0 \leq f \leq 1$

We concentrate the mathematical analysis on the calculation of  $R_0$  and its dependence on measures that can be controlled, specifically the quarantine rate. We notice that as soon as the epidemic starts, farmers begin to apply quarantine measures, and thus the average number of secondary infections produced by an infected farm will begin to change. We first derive an expression for the average number of infections caused by an infected farm as a function of the current number of infected farms, maximize its value and use this as  $R_0$ . We apply the method of Hernández [2] for the calculation of  $R_0$ .

### 2.1.6 Calculation of $R_0$

According to Hernández [2] we have to divide the possible states of farms into active infectious, passive infectious and all other states. Hernández's definition implies that farms are in an active infectious state if they can produce new infections through direct contact, and in a passive infectious state if they can reach an active infectious state without secondary infection. In our model, the only active infectious farms are those in state  $I$ , whereas the passive infectious farms are those in state  $L$ . All other states are in the class  $\Delta$ . The state-dependent matrix of transition probabilities between the three states is:

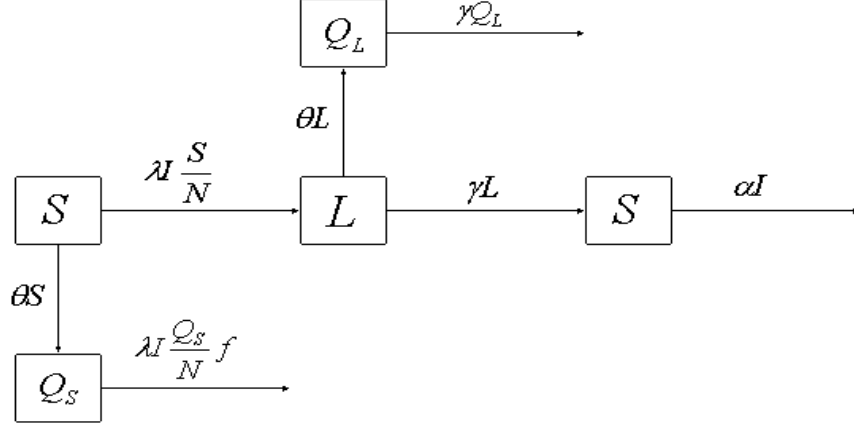

Figure 2: SLI FMD Model (Owners of Farms Quarantine Practice)

$$F(I) = \begin{pmatrix} I & L & \Delta \\ 0 & 0 & 1 \\ \frac{\gamma}{\gamma+\theta} & 0 & \frac{\theta}{\gamma+\theta} \\ 0 & 1 - \frac{\theta}{\theta + \frac{\lambda I}{N}} & \frac{\theta}{\theta + \frac{\lambda I}{N}} \end{pmatrix}$$

The last row of the above matrix requires an explanation: a susceptible farm can enter the state of infection through state  $L$ , but due to quarantine it may enter state  $\Delta$  before it is infected. Thus, we are taking the effect of quarantine into account. However, the strength of this effect also depends on the number of infectious farms, which are “pulling” susceptible farms to the latent state. Since the individual quarantine rate is  $\theta$ , and the rate of farm removal is  $\lambda \frac{I}{N}$ , the probabilities in the last row of  $F(I)$  follows directly. The expected average time a farm spends in the infectious state when there are exactly  $I$  infected farms is denoted by  $E(T_i)$ , and is computed as follows by applying the technique from Hernández. [2]:

$$E(T_i) = \frac{\lambda \gamma I}{\alpha(\gamma + \theta)(N\theta + \lambda I)} \quad (21)$$

Hence, the matrix of transition probabilities depends on the actual number of infectious farms. The reproductive number  $R$  as a function of  $I$  is the contact rate,  $\lambda$ , multiplied by the probability that a contact is with a susceptible farm. Under the worst-case scenario, this probability is maximized when the number of susceptible is  $N - I$ . Therefore, the effective contact rate is  $\lambda \frac{N-I}{N}$ . It follows that the reproductive number as a function of  $I$  is:

$$R(I) = \frac{\lambda^2 \gamma I (N - I)}{[\alpha(\gamma + \theta)(N\theta + \lambda I)]N} \quad (22)$$

We clearly see that this  $R(I)$  is monotonically decreasing with the quarantine rate. As can be shown with elementary calculus, the value of  $I$  that maximizes  $R(I)$  is:

$$Max(I) = \frac{N\sqrt{\theta(\theta + \lambda)}}{\theta} \quad (23)$$

and the value of  $R$  at this point is:

$$R(I^*) = \frac{\gamma(2\theta + \lambda - \frac{2\theta^{3/2} + 2\lambda\sqrt{\theta}}{\sqrt{\theta + \lambda}})}{\alpha(\gamma + \theta)} \quad (24)$$

Thus, a lower bound for the probability of extinction is  $min(1, R(I^*))$ . By setting the above expression for the *maximum* equal to one and solving for the quarantine rate, we find the *minimum* value of  $\theta$ , which is given by

$$\theta = \frac{\gamma(\alpha - 2\gamma - \lambda + 2\sqrt{\frac{\gamma(\alpha(\gamma - \delta) + \lambda^2)}{\alpha}})}{4\gamma - \alpha} \quad (25)$$

We consequently have used the stochastic model to derive an expression for the minimal quarantine rate that keeps the maximum value of  $R$  below one. This value of  $\theta$  is extremely important because it gives policy decision makers an effective but not overly intrusive quarantine rate.

## 2.2 Stochastic Computer Simulation Model

The problem with the two previous formulations is that by assuming random mixing, they fail to realistically model the spread of FMD across an entire country such as Uruguay. In our third approach we assume non-random mixing, and we hope to

formulate a realistic model with more practical policy implications. When an FMD epidemic begins in Uruguay, the first response is to try to eliminate it with a “stamping out” policy in which quarantine and slaughter are localized around infected farms [1]. If this first response fails, an expensive national vaccination program is implemented. It is known that outbreaks starting from certain areas can be contained fairly easily through stamping out, but that index cases in other regions can create epidemics that are much harder to control. The goal of our simulation model is to partition the counties of Uruguay into those for which stamping out would be an effective response to an index case, and those where vaccination might be necessary. Clearly, such a partition would not be possible in a random-mixing model as the expected epidemic size would be independent of the index case location.

The basic epidemiological unit in the stochastic simulation model is not a cow or a farm, but now an entire county. That is, we require that entire counties must be in susceptible, latent, infected, quarantined, or slaughter states and we assume all cows in a county are always in the same state. The model can incorporate parts of an FMD epidemic that are not possible in the previous two models, such as the distances between counties (measured from the centroids), the traffic between counties, the size of each different county (number of cows), and the breakdown of cows in each county (dairy or beef). We also change the model from continuous time to discrete time, with the unit time interval being one day. We justify this change because we assume that for a quickly spreading epidemic such as FMD, policymakers must often decide what actions are needed for the next day.

Each of the counties in Uruguay can produce a random number of infectious “agents” each day in our model. An agent is a truck, airplane, person, or anything that can potentially leave the county and infect another county. Each agent from an infected county can reach any of the counties with a “connection” to the infected county with a certain probability during the day that it is produced, but no later. A “connection set” is the set of counties that it can potentially infect. The number of agents produced by an infected county is independent of what happens that day on any other county, or of any events in the past. Likewise, whether an agent produced from an infected farm reaches a certain farm in its connection set is independent of all other events. Once a county is infected, it is latent for a fixed number of days, and cannot transmit infection. After the latent period it can transmit infection, but is not noticed by public health authorities in our model for a fixed number of days. Once the infection is noticed, all cows in a county are immediately slaughtered, and from that point forward the county is removed from the model. After the first infected farm is recorded, a quarantine policy begins so that each farm can no longer transmit infection because it is removed from the model. This independent quarantining deviates from the actual practice of localizing control measures around a source case, but permits the study of more severe outbreaks as in the random-mixing models. We assume that only cattle, and not swine, sheep, or other animals are responsible for the spread of FMD.

### 2.2.1 Model Formulation

Our simulations model uses a large number of parameters and assumptions which are defined below:

$n$  = Number of counties in Uruguay

$D_{ij}$  = Distance between the  $i$ th and  $j$ th counties.  $i, j = 1, \dots, n$

$BE_i$  = Number of beef cows in the  $i$ th county.  $i = 1, \dots, n$

$DA_i$  = Number of dairy cows in the  $i$ th county.  $i = 1, \dots, n$

$\beta_1$  = Rate of infectious agents per beef cow, per day produced in an infected county

$\beta_2$  = Rate of infectious agents per dairy cow, per day produced in an infected county

$\theta_i$  = Average number of infectious agents per day from the  $i$ th farm.  $i = 1, \dots, n$

$$\theta_i = \beta_1 BE_i + \beta_2 DA_i$$

$\gamma$  = length of the latent period, where the infected cows cannot transmit the infection

$d$  = length of time between a county becoming infected and being noticed as infected

$\alpha$  = rate at which farms are quarantined after the first infected farm is noticed

$Z$  = Number of days after the first noticed infection for a given farm to be quarantined

$Z \sim \text{Geometric}(\alpha)$  (Modeling assumption, consistent with the previous stochastic model)  $\text{Prob}(Z = k) = \alpha(1 - \alpha)^{k-1}, k = 1, 2, \dots$

$\lambda$  = Rate ( $1/\text{distance}$ ) at which an infectious agent can infect a county in the connection set of the infected county. For  $i, j = 1, \dots, n$  we have the following

$Y_{ij}$  = Distance that an agent travels from  $i$ th farm in the direction of the  $j$ th farm per day.

$Y_{ij} \sim \text{exponential}(\lambda)$  (Modeling assumption)

$Q_{ij}$  = Probability(Agent from  $i$ th county reaches  $j$ th county in a day —  $i$ th county infected)

$$Q_{ij} = \text{Prob}(Y_{ij} > D_{ij}) = e^{-\lambda D_{ij}}$$

$X_i$  = Number of agents produced on the  $i$ th county per day.  $i = 1, \dots, n$

$X_i \sim \text{Poisson}(\theta_i)$  (Modeling assumption, as the *Poisson* distribution is often used for counts)  $\text{Prob}(X_i = k) = \frac{1}{k!} e^{-\theta_i} \theta_i^k$

$P_{ij}$  = Probability(An agent from the  $i$ th county reaches  $j$ th county in a day —  $i$ th infected).  $i, j = 1, \dots, n$

$$P_{ij} = 1 - P(\text{All } X_i \text{ agents independently fail to reach the } j\text{th county})$$

$$= 1 - \text{Prob}(\text{A Poisson}(\theta_i; Q_{ij}) \text{ random variable is zero})$$

$$\text{Using well-known properties of the Poisson process, } = 1 - e^{-\theta_i Q_{ij}} = 1 - e^{-\beta_1 BE_i + \beta_2 DA_i} e^{-\lambda D_{ij}}$$

In estimating parameters for the model formulated above, we were unable to find referenced values for all quantities. Thus, we made several approximations, as explained below. However, the point of the simulation model is to provide a tool to policymakers who have data for values that we approximate, such as the distribution of beef and dairy cattle across the different counties. When assigning county-specific attributes such as a connection set or beef/dairy breakdown, we make assignments such that the expected number is the same for all counties. Our assumptions are conservative because they assume regional homogeneity. This is a conservative assumption as the simulations are designed to find regional differences in quarantining

effectiveness.

### 2.2.2 Model Parameters

We use the following values for the respective parameters to run the simulations:

$$n = 274$$

$$\beta_1 = 5 \times 10^{-4}, \beta_2 = 7\beta_{be}$$

It is assumed that trucks can enter a county to pick up milk every day, but estimate that beef cows are taken to meat packing once a week, so the agent production rate should be higher for dairy cows. This discrepancy is confirmed by empirical evidence from Ariel Rivas.

$$\gamma = 4$$

This is within the range for the latent period.[3]

$$d = 9$$

This is within the range for the infectious period.[4]

$\alpha = 0.0488$  This is a modeling assumption.

$$\lambda = 5.8079 \times 10^{-5}$$

This is a modeling assumption. We here assume that  $1/\lambda$  is the average distance between neighboring counties, so that on average an infected agent can reach the closest county, roughly half of the time.

$D_{ij}$  = Coordinates of the centroids of each county are known (Ariel Rivas). Using  $D_{ij}$ , we calculate the Euclidean distance matrix between counties. However, we assume that each county can only pass infectious agents to the counties in its infection set. Using the explicit road system in Uruguay would improve our simulations. Here, we only implement a Monte Carlo approximation (see the Matlab code in appendix B for details).

For parameters  $BE_i, DA_i$ , We know that Uruguay has approximately 10.7 million beef cattle and 403000 dairy cattle [5, 6]. We do not know how these are distributed among the counties, so we randomly assign them. Hence each county has the same expected number of beef and dairy cattle. (See the Matlab code in Appendix A for details).

### 2.2.3 Results

From this formulation we can now simulate the epidemic by placing the index case in one of the  $n$  counties. A county can infect other counties in its connection set if it is not latent, quarantined, or slaughtered. The counties in the connection set of an infected county are infected each day with probability  $P_{ij}$  unless they are quarantined, and quarantining begins after the first infected farm is recorded. We simulate the epidemic for only 31 days because FMD is a quickly spreading epidemic. After many simulated epidemics, the output is an  $n \times 31$  matrix where the  $(i, j)$  entry is the estimated probability that the  $i$ th county is contaminated with FMD by the  $j$ th

day. Estimated probabilities are obtained by averaging over many simulations.

We run the simulation with the index cases in county 1 and in county 265, each for 250 simulations. Some of the output is given graphically on the following pages, where we have assigned an indexing number to each county of Uruguay. The outbreak is fairly well contained when it starts from county 1, as we can see from the attached plots that most of the counties have an extremely low probability of infection after the first month. However, when the source is in county 265 then mass vaccination would be a preferable option to quarantining, because the quarantining clearly fails to control the epidemic. For both sources we can see that from roughly halfway through the month (day 16) the disease has already spread to counties with close indices, but has not yet infected many of the other counties that it reaches by day 31.

We also define  $W_i$  as the probability that a randomly chosen county in Uruguay is infected after 31 days, conditioning on the index case being from the  $i$ th county. The quantity  $W_i$  is a measure of how effective the quarantine policy is for the  $i$ th possible index case location, and it is calculated by averaging the final row of the output matrix described above. We iterate through each of the 274 counties of Uruguay and estimate  $W_i, i = 1, 2, \dots, 274$ . From the histogram of these estimates we see that quarantining does not appear to be a generally effective policy option for FMD. This is because most counties have a better than even chance of becoming infected after a month, from well over half of the source counties. However, we see from the plot of ( $i$  vs.  $W_i$ ) that  $W_i$  remains small for  $i \leq 50$ , so the simulations discover regions of Uruguay where a stamping out policy might be effective.

### 3 Discussion

When creating a national control policy for a rapidly spreading epidemic such as FMD disease, policymakers in Uruguay must rely on mathematical modeling of proposed disease responses. Formulating models to inform policy decision makers necessitates making tradeoffs between mathematical tractability and realistic epidemiological assumptions. In this work, we illustrate the usefulness of three models with various degree of mathematical simplification. In doing so, we demonstrate how different problems related to FMD disease control can be based on epidemiological analysis with varying degrees of realistic biological assumptions.

Our first model is mathematically tractable, as it models the cattle populations in Uruguay using two patches that differentiate between the types of cows (beef and dairy). The basic epidemiological unit is the cow. The model is a system of nonlinear ordinary differential equations. From this model, we give conditions for disease invasion via the basic reproductive number. The model assumes random mixing, and is hence, may be useful in the study the worst-case scenarios. We use analytical results to suggest that faster screening methods for FMD may be useful in the FMD outbreak.



The second model is a stochastic continuous time Markov chain model, where the basic epidemiological unit is the farm. This model still assumes random mixing, and allows random effects. We compute the reproduction number  $R_0$  as a function of the number infected, and we capture dynamics of an index case not necessarily spreading the most infections. The model remains somewhat mathematically tractable. We can obtain an explicit expression for the minimum necessary rate of quarantining farms to control the outbreak in some cases. This expression may be useful, because excessive quarantining and restriction on travel can cause economic harm.

The third model is an explicit stochastic simulation that incorporates more realistic biological dynamics, but models FMD with a complex mathematical structure that cannot be studied analytically. The basic epidemiological unit is now the county, time is measured in days and the simulation is updated every day. We model infected counties spreading the disease to other counties such that transmission depends on intra-county distance, traffic between counties, county size, and the beef/dairy breakdown in counties. The model also allows us to address the real problem of partitioning the counties of Uruguay into those for which quarantining would be an effective response to an index case. This is a practical solution because an expensive massive national vaccination is necessary when stamping out policies fail to contain the epidemic. Simulation allows us to control costs by identifying Uruguayan regions where stamping out is likely to succeed.

The three models in this work have their respective merits and disadvantages. FMD causes severe economic devastation for Uruguay, and as such poses a variety of modeling challenges. Our models theoretically suggest that faster individual screening may be useful in FMD control, give an expression for an optimal quarantine policy, and offer practical advice as to where stamping out is an effective response. Our modeling results illustrate how different problems related to FMD can be solved with models that try to reach a compromise between analytic tractability and reality.

## 4 Acknowledgments

This research has been partially supported by grants given by the National Science Foundation, National Security Agency, and the Sloan Foundation (through the Cornell-Sloan National Pipeline Program in the Mathematical Sciences). Substantial financial and moral support was also provided by the Office of the Provost of Cornell University, the College of Agriculture & Life Science (CALs), and the Department of Biological Statistics & Computational Biology. The authors are solely responsible for the views and opinions expressed in this research; it does not necessarily reflect the ideas and/or opinions of the funding agencies and/or Cornell University. We give special thanks to Zhilan Feng, Ariel Rivas, Michael Lanham, Carlos Castillo-Garsow, and Sophonie Nshinyabakobeje for their useful comments and suggestions.

## 5 Appendix A

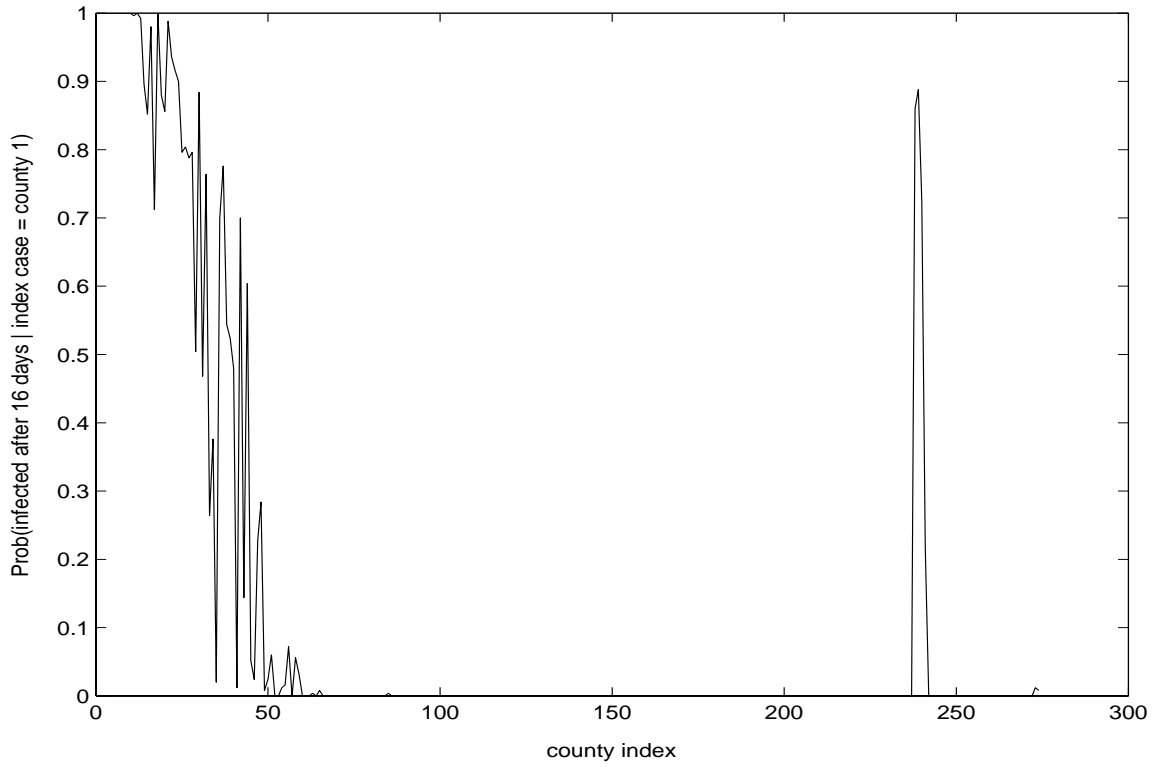

Figure 3: Stochastic FMD Model

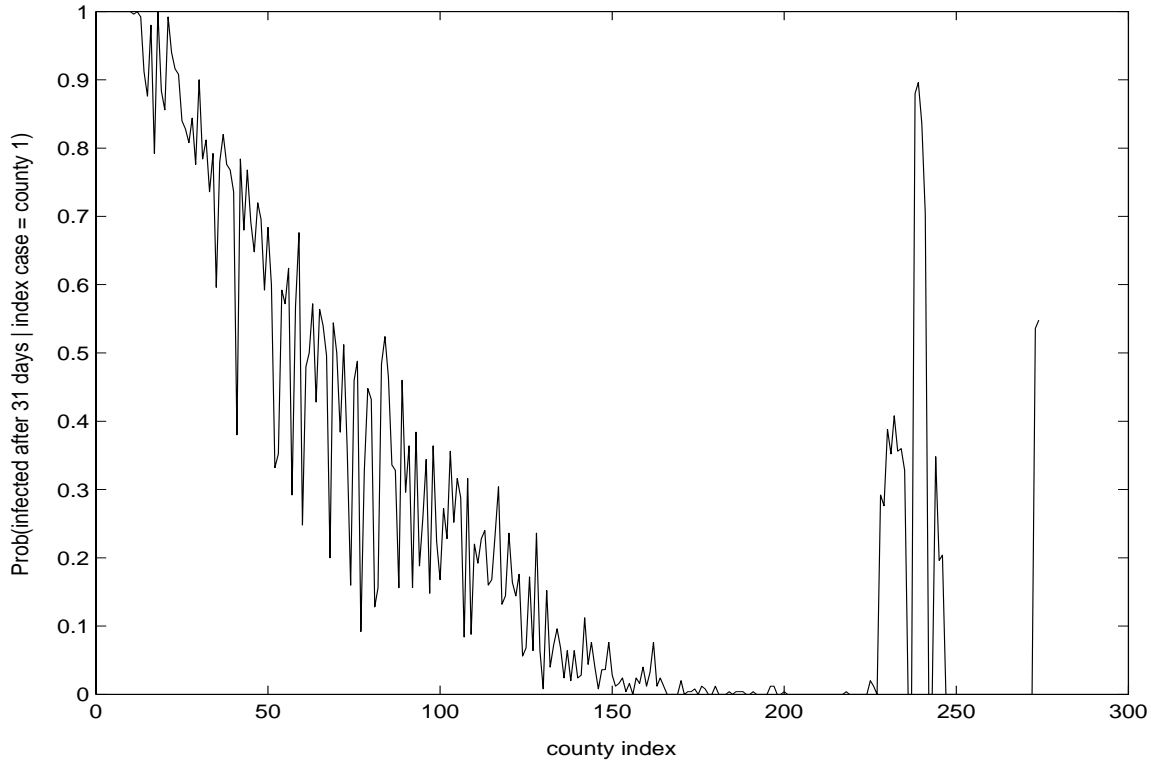

Figure 4: Stochastic FMD Model

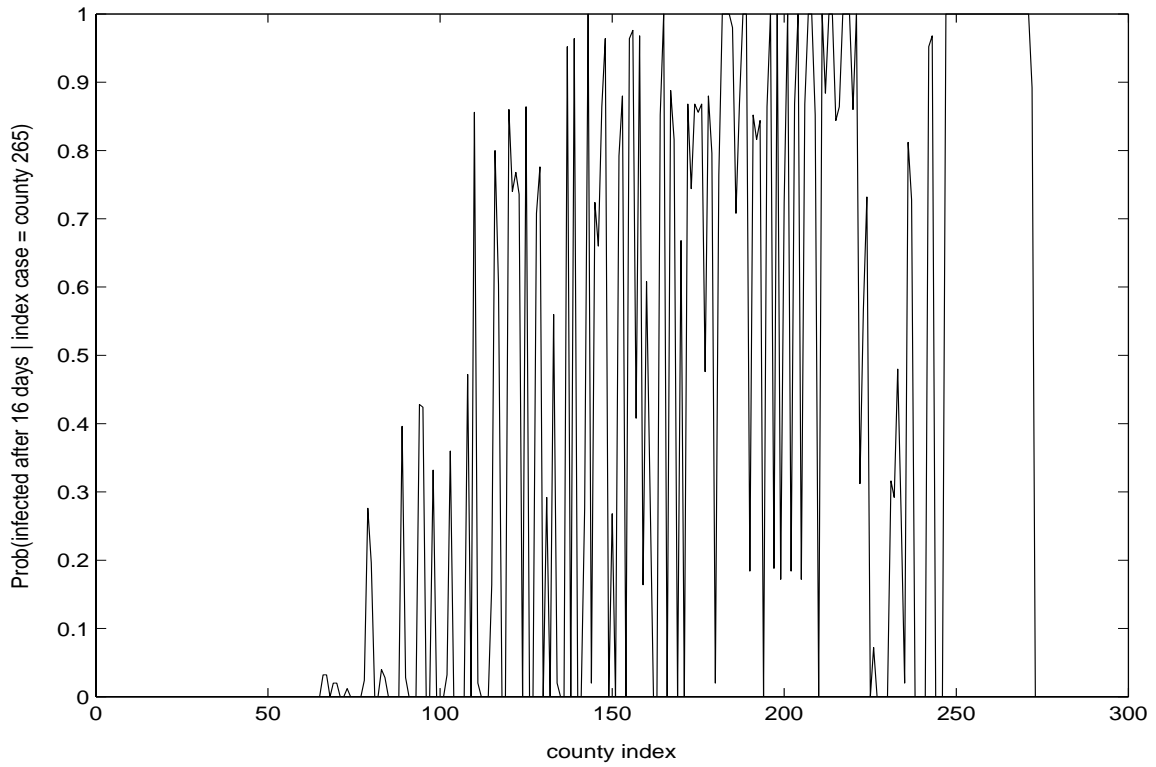

Figure 5: Stochastic FMD Model

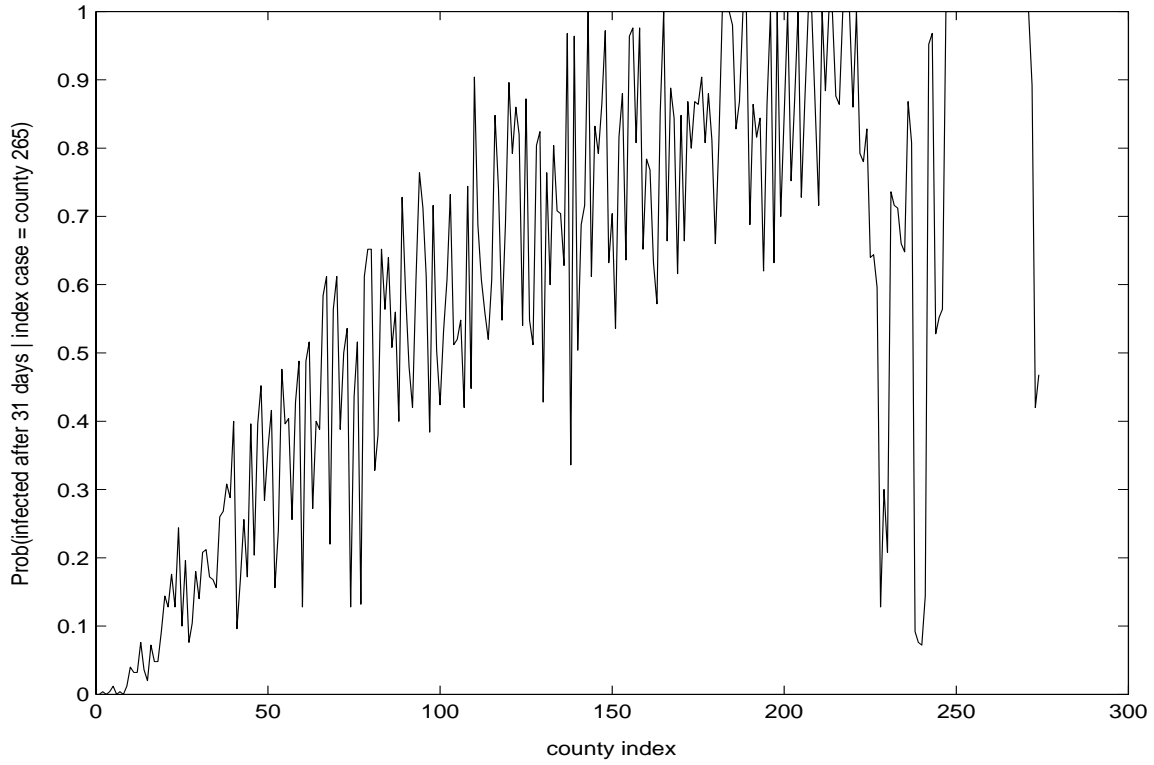

Figure 6: Stochastic FMD Model

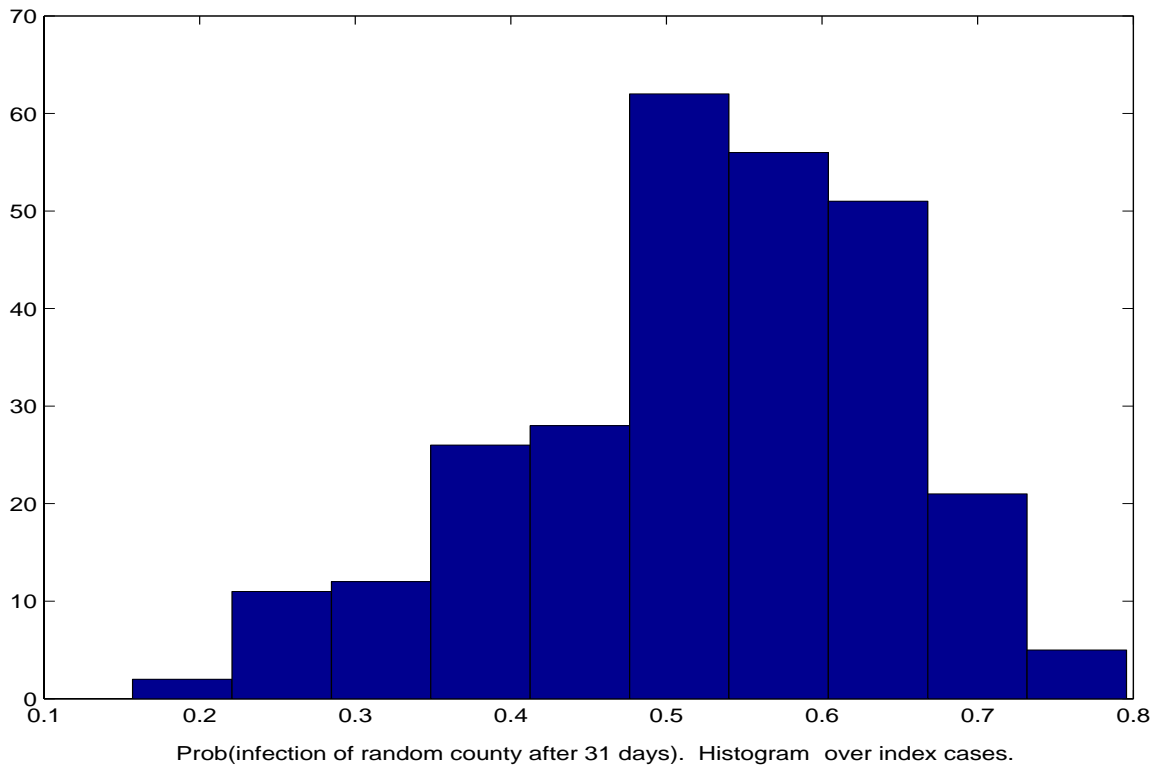

Figure 7: Stochastic FMD Model

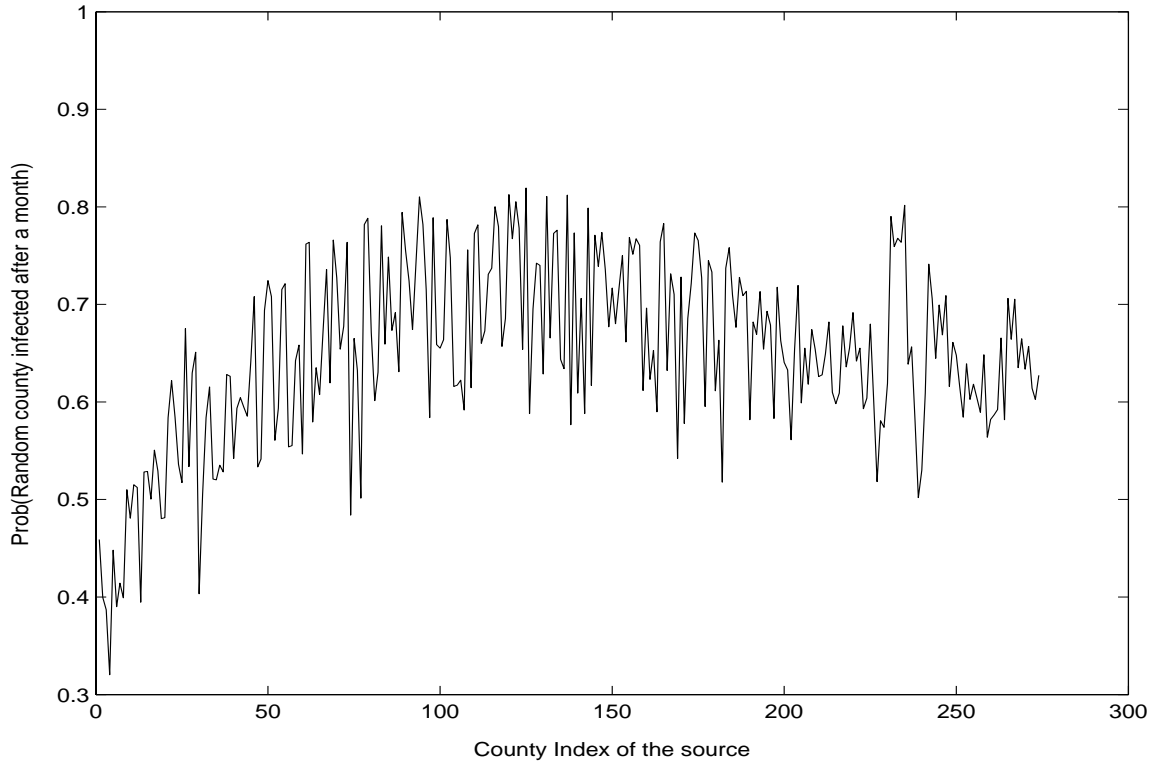

Figure 8: Stochastic FMD Model

In the following we present the *MatLab* code used for the computer simulation model. Our comments explain the input and output of each function.

```
function [out1, out2] = RunSimulations(n, totalDairy, totalBeef,
dairyRate, beefRate, D, lambda, source, steps, l, d, numQuar, numSim)
```

```
[T, S] = InitializeTraffic(totalDairy, totalBeef, dairyRate,
beefRate, lambda, D, n);
```

```
[out1, out2] = Simulations(T, n, source, steps, l, d,
numSim, numQuar, S, D, Qind);
```

```
% Arguments: -----
% n = Number of counties
% totalDairy = Total number of dairy cattle in Uruguay
% totalBeef = Total number of beef cattle in Uruguay
% dairyRate = Average number of infectious agents per dairy
%             cow, per day from an infected county
% beefRate = Average number of infectious agents per beef
%            cow, per day from an infected county
% D = Distance matrix where D(i,j) is the distance between
```

```

%     county i and county j
% lambda = parameter of the exponential distribution that
%         governs how far an infectious agent can travel
%         in a day
% source = index of the first infected county in the
%         FMD epidemic
% steps = Number of days for which to simulate an epidemic
% l = length of the latent period
% d = length of time between a county encountering the virus
%     and being noticed and slaughtered by national
%     public health authorities
% numQuar: 1-exp(-numQuar) is the parameter of the geometric
%         distribution governing how long it takes after for
%         a county to be quarantined after the FMD epidemic
%         is noticed in Uruguay.
% numSim = Number of simulations of an epidemic to run.

% Output: -----
% out1 = A nxsteps matrix where out1(i,j) is the estimated
%         probability that the ith county is infected by the
%         jth day of the FMD epidemic.
% out2 = A 1xnumSim vector where out2(i) is the number of
%         infected counties after steps days in the ith
%         simulated epidemic.

function [out1, out2] = Simulations(T, n, source, steps, l, d,
numSim, numQuar, S, D)

out1 = zeros(n, steps);
out2 = zeros(1, numSim);
for i=1:numSim,
    [result1, result2] = Epidemic(T, n, source, steps, l,
    d, numQuar, S, D);
    out1 = out1 + result1;
    out2(i) = result2;
end
out1 = out1/numSim;

% Arguments: -----
% T, S: As defined in InitializeTraffic
% All others: As defined in RunSimulations
% Output: As defined in RunSimulations

function [out, deadCattle] = Epidemic(T, n, source,

```

```

steps, l, d, numQuar, S, D)

out = zeros(n, steps);
I = zeros(1, n);
I(source) = 1;
DI = zeros(1, n);
Q = zeros(1, n);
for i=1:steps,
    [I, DI, Q] = NextDay(I, DI, Q, T, n, l, d, numQuar, D);
    out(:,i) = I';
end
deadCattle = sum(I);

% Arguments: -----
% T,S: As defined in InitializeTraffic
% All others: As defined in RunSimulations
% Output: -----
% out = An nxsteps matrix where out(i,j) is an indicator of
%        whether the ith county is infected on the jth day
%        of the simulated epidemic.
% deadCattle = The number of farms that have been infected
%              after steps days of the epidemic.

function [Inew, DInew, Qnew] = NextDay(I, DI, Q, T, n,
l, d, numQuar, D)

Qnew = UpdateQ(I, DI, Q, T, n, l, d, numQuar, D);
potentialInfectious = zeros(1, n);
potentialInfectious = I == 1 & DI >= l & DI < d & Qnew == 0;
Inew = I;
DInew = DI;
for i=1:n,
    if (Inew(i) == 0 & Q(i) == 0),
        Ri = potentialInfectious*T(:,i);
        Inew(i) = binornd(1, 1-exp(-Ri));
    end
    if (Inew(i) ~= 0)
        DInew(i) = DI(i) + 1;
    end
end

% Arguments: -----
% I = A 1xn vector where I(i) is an indicator of whether the
%     ith county is currently infected in the epidemic.

```

```

% DI = A 1xn vector where DI(i) gives the number of days for
%       which the ith county has been infected at the current
%       point in the epidemic.
% Q = A 1xn vector where Q(i) is an indicator of whether the
%       ith county is currently quarantined in the epidemic.
% All others: As defined in RunSimulations
% Output: Inew, DInew, Qnew are the updated versions of
%         I, DI, and Q after the next day in the epidemic.

```

```

function Qnew = UpdateQ(I, DI, Q, T, n, l, d, numQuar, D)

```

```

Qnew = Q;
if (max(DI) >= d),
    Qnew = binornd(1, 1-exp(-numQuar), 1, n);
    Qnew = Q == 1 | Qnew == 1;
end

```

```

% Arguments: I, DI, Q are as defined in NextDay.
%           All other arguments are as defined
%           in RunSimulations.
% Output: Qnew is as defined in NextDay.

```

```

function [Dnew, lambda] = MakeDnew(D, n, numCon)

```

```

for i=1:n,
    for j=1:i,
        D(i, j) = D(j, i);
    end;
end

```

```

numConnections = poissrnd(numCon, 1, n) + 1;
Dnew = zeros(n, n);
for i=1:n,
    [dummy, newRow] = sort(D(i,:));
    for j=1:numConnections(i),
        nextIndex = geornd(1/numConnections(i)) + 2;
        Dnew(i, newRow(nextIndex)) = D(i, newRow(nextIndex));
        Dnew(newRow(nextIndex), i) = D(i, newRow(nextIndex));
    end
end
for i=1:n,
    for j=1:n,
        if (i ~= j & Dnew(i,j) == 0),

```



```

        Dnew(i,j) = inf;
    end;
end;
end;

DnewSorted = sort(Dnew);
lambda = 1/mean(DnewSorted(2,:));

% Arguments: -----
% D = A lower triangular distance matrix where if  $i \leq j$  then
%     D(i,j) is the geographic distance between the centroids
%     of the  $i$ th and the  $j$ th counties.
% n = The total number of counties in Uruguay.
% numCon = One less than the average number of counties in the
%          connection set of a randomly chosen county.
% Output: As defined in RunSimulations

function [out1, out2] = CowAssignments(numDairy, numBeef, n)

X = sort(unifrnd(0, numDairy, 1, n));
X = [0 X numDairy];
Y = sort(unifrnd(0, numBeef, 1, n));
Y = [0 Y numBeef];
out1 = zeros(1, n);
out2 = zeros(1, n);
for i=2:(n+1),
    out1(i-1) = X(i) - X(i-1);
    out2(i-1) = Y(i) - Y(i-1);
end

% Arguments: -----
% numDairy = Total number of dairy cows in Uruguay
% numBeef = Total number of beef cows in Uruguay
% n = Total number of counties in Uruguay
% Output: -----
% out1 = A 1xn vector where out1(i) is the number of
%        dairy cows in the  $i$ th county.
% out2 = A 1xn vector where out2(i) is the number of
%        beef cows in the  $i$ th county.

function [T, S] = InitializeTraffic(totalDairy, totalBeef,
dairyRate, beefRate, lambda, D, n)

```

```

alpha = zeros(1, n);
S = zeros(1, n);
[numDairy, numBeef] = CowAssignments(totalDairy, totalBeef, n);
for i=1:n,
    alpha(i) = numDairy(i)*dairyRate + numBeef(i)*beefRate;
    S(i) = numDairy(i) + numBeef(i);
end

T = zeros(n, n);
for i=1:n,
    for j=1:n,
        T(i,j) = alpha(i)*exp(-lambda*D(i,j));
        if (D(i,j) == inf),
            T(i,j) = 0;
        end
        if (i == j)
            T(i, j) = 0;
        end;
    end
end

% Arguments: As defined in RunSimulation
% Output: -----
% T = An nxn matrix where 1-exp(-T(i,j)) is the probability
%       that an infectious agent from county i will reach county
%       j in a day, conditioned on the event that county i
%       is infected.
% S = A 1xn matrix where S(i) is the total number of cattle
%       in the ith county.

function probs = PartitionCountry(n, totalDairy, totalBeef,
dairyRate, beefRate, D, lambda, steps, l, d, numQuar, numSim)

probs = zeros(1, n);
for i=1:n,
    source = i;
    [out, dummy] = RunSimulations(n, totalDairy, totalBeef,
dairyRate, beefRate, D, lambda, source, steps, l, d, numQuar, numSim);
    probs(i) = sum(out(:,steps)/n)
end;

% Arguments: As defined in RunSimulations.
% Output: probs is a 1xn vector where probs(i) is the estimated

```

% probability that a randomly chosen county is infected  
% after steps days of the epidemic, conditioning on the  
% event that the index case is from source.

## References

- [1] CDC: Fact Sheet: Dengue and Dengue Hemorrhagic Fever. June 19, 2001. World Wide Web. <http://www.warmwell.com/aop27uruguayemb.htm>
- [2] Hernandez-Surez, C. M., *A Markov Chain Approach to Calculate  $R_o$  in Stochastic Epidemic Models*, Journal of Theoretical Biology 215, 83-93.
- [3] Haydon, D.T., and M.E.J. Woolhouse. 1997. *An analysis of foot-and-mouth disease epidemics in the UK.*, Journal of Mathematics Applied in Medicine and Biology 14: 1-9.
- [4] Burrows, R. 1968. *Excretion of foot-and-mouth disease virus prior to the development of lesions*, The veterinary record 82: 387-388.
- [5] ([http://www.aphis.usda.gov/vs/ceah/cei/fmd\\_uruguay1000e.htm](http://www.aphis.usda.gov/vs/ceah/cei/fmd_uruguay1000e.htm))
- [6] [http://www.comasul.com/lechero/glechero\\_i.html](http://www.comasul.com/lechero/glechero_i.html))
- [7] Friedman, J.H., Rafsky, L.C., multivariate generalizations of the wald-wolfowitz and smirnov two-sample tests, Annals of Statistics, 7, 4, 1979, 697-71
- [8] Rivas, Ariel. July, 2002 Personal Correspondence
- [9] *United States Department of Agriculture and Animal and Plant Health Inspection Services.* , *Veterinary Services Emergency Program Issued November 1992 Slightly revised in October 1995.*  
[http://www.aphis.usda.gov/vs/ep/fad-training/VESVOL7/page\\_08.7.htm](http://www.aphis.usda.gov/vs/ep/fad-training/VESVOL7/page_08.7.htm),
- [10] *USDA, March 2001.*  
[www.aphis.usda.gov/oa/fmd/fsfmd.301.htm](http://www.aphis.usda.gov/oa/fmd/fsfmd.301.htm).
- [11] *USDA, March 2002.*  
[www.aphis.usda.gov/oa/pubs/fsfmdpre.htm](http://www.aphis.usda.gov/oa/pubs/fsfmdpre.htm).
- [12] *USDA, January 2002.*  
[www.aphis.usda.gov/oa/pubs/fsfmdres.htm](http://www.aphis.usda.gov/oa/pubs/fsfmdres.htm).
- [13] *USDA, January 2002.*  
[www.aphis.usda.gov/oa/pubs/fsfmdvac.htm](http://www.aphis.usda.gov/oa/pubs/fsfmdvac.htm).
- [14] *World Organization for Animal Health, Updated.22.04.2002.*  
<http://www.oie.int/eng/maladies/fiches/A.A010.HTM> .

- [15] *Agriculture and Animal-Health Canada, November 1996.*  
[http://epix.hazard.net/topics/animal/f - m\\_d.htm](http://epix.hazard.net/topics/animal/f - m_d.htm).
- [16] *Direccin General de Sanidad y Proteccin de los Consumidores Bruselas, 9 de octubre de 2001.*  
[http://europa.eu.int/comm/dgs/health-consumer/library/press/press194\\_e.s.htm](http://europa.eu.int/comm/dgs/health-consumer/library/press/press194_e.s.htm).
- [17] *USDA, April 26, 2001.*  
<http://embeeuu.gub.uy/aftosa.htm>.
- [18] Hernandez-Suarez, Carlos M. *A Markov Chain Approach to Calculate Ro in Stochastic Epidemic Model.*, Revised, November 19,2001.
- [19] B. Fred & C. Castillo-Chávez , *Mathematical Models in Population Biology and Epidemiology* , Springer, p416, 2001.
- [20] Ross, Sheldon M., *Introduction to Probability Model*, Academic Press, p669, 1997.